

CITY OF ALBANY
DEPARTMENT OF PUBLIC WORKS

DIVISION E

STORMWATER MANAGEMENT ENGINEERING STANDARDS



Prepared By

**PUBLIC WORKS DEPARTMENT
ALBANY, OREGON 97321**

Telephone: (541) 917-7676

February 2024

TABLE OF CONTENTS

E 1.00 – GENERAL	1
E 1.01 PURPOSE	1
E 1.02 SHORTENED DESIGNATION	1
E 1.03 APPLICABILITY	2
E 1.04 REFERENCES	2
E 1.05 STANDARD CONSTRUCTION SPECIFICATIONS	2
E 1.06 DEFINITIONS AND TERMS	2
E 2.00 – STORMWATER PLAN	6
E 2.01 STORMWATER REPORT AND SITE PLANS	6
E 2.02 EXISTING STORMWATER SITE PLAN	6
E 2.03 PROPOSED STORMWATER SITE PLAN	7
E 3.00 – STORMWATER QUALITY	7
E 3.01 GENERAL REQUIREMENTS	7
E.3.02 STORMWATER QUALITY GENERAL DESIGN REQUIREMENTS	8
E 3.03 FACILITY SELECTION AND LOCATION	11
E 3.04 STORMWATER QUALITY FACILITY SIZING	14
E 3.05 STORMWATER QUALITY FACILITY DESIGN CRITERIA	21
E 3.06 LANDSCAPE REQUIREMENTS	33
E 3.07 OPERATION & MAINTENANCE	37
E 4.00 – STORMWATER QUANTITY MANAGEMENT DESIGN & CALCULATIONS	38
E 4.01 GENERAL REQUIREMENTS	38
E 4.02 RUNOFF CALCULATIONS AND SYSTEM CAPACITY	39
E 4.03 SUPPORTING DATA	40
E 5.00 – PIPES AND CLOSED CONDUIT	41
E 5.01 GENERAL	41
E 5.02 PIPE SIZE	41
E 5.03 GRADE	41
E 5.04 ALIGNMENT	42
E 5.05 COVER REQUIREMENTS	42
E 6.00 – INLETS, OUTLETS, CONNECTIONS	43
E 6.01 CURB INLETS	43
E 6.02 SURFACE DRAINAGE INTERCEPTION	43
E 6.03 SLOPE INTERCEPT INLETS	43
E 6.04 SUBSURFACE DRAINAGE INTERCEPTION	43
E 6.05 OUTLETS INTO SURFACE DRAINAGE CHANNELS	44
E 6.06 MANHOLES	44
E 7.00 – SURFACE DRAINAGE	45
E 7.01 SURFACE DRAINAGE	45
E 7.02 CONSTRUCTED WATERCOURSE REQUIREMENTS	45
E 7.03 NATURAL CREEK REQUIREMENTS	46
E 8.00 – STORMWATER DETENTION	46
E 8.01 GENERAL REQUIREMENTS	46

E 8.02	SURFACE PONDS	47
E 8.03	CLOSED DETENTION SYSTEM	49
E 8.04	DETENTION POND EASEMENTS	49
E 9.00	– EROSION PREVENTION AND SEDIMENT CONTROL.....	49
E 9.01	EROSION PREVENTION AND SEDIMENT CONTROL.....	49
E 10.00 – APPENDICES		
E 10.01	24-HOUR RAINFALL FOR ALBANY	
E 10.02-A	SHALLOW CONCENTRATED FLOW VELOCITY	
E 10.02-B	RAINFALL INTENSITY-DURATION FREQUENCY CURVES	
E.10.03	PLANTING MATRIX AND PLANTING DIAGRAM EXAMPLES	
E.10.04	OPERATIONS AND MAINTENANCE AGREEMENT AND CHECKLISTS	
E.10.05	WATER QUALITY FACILITY DESIGN GUIDE DRAWINGS	
E.10.06	INFILTRATION TESTING AND GROUNDWATER INVESTIGATIONS	

DIVISION E – STORMWATER MANAGEMENT

E 1.00 – GENERAL

E 1.01 PURPOSE

The purpose of these Stormwater Management Engineering Standards is to provide a consistent policy under which certain physical aspects of stormwater management will be implemented. Most of the elements contained in this document are Public Works oriented and most are related to the development or platting process; however, it is intended that they apply to both public and private work designated herein.

These Engineering Standards cannot provide for all situations. They are intended to assist, but not to serve as a substitute for competent work by design professionals. Engineers are expected to bring the best skills from their respective disciplines to each project. If the Engineer anticipates challenges in meeting these standards, they should contact the City prior to extensive design efforts.

These Engineering Standards are not intended to limit unreasonably any innovative or creative effort that could result in better quality, better cost savings, or both. Any proposed departure from the Engineering Standards will be judged on the likelihood that such variance will produce a compensating or comparable result, in every way adequate for the user and City over the life cycle of the improvement.

Note that the presentation, layout, and general configuration of all engineering design drawings shall be in conformance with Albany's drafting design criteria as outlined in Division A of the Engineering Standards. Engineers shall prepare project design drawings in conformance with the requirements contained therein.

The standards have the objective of developing a stormwater management system that will:

- A. Be of adequate design to safely manage stormwater generated upstream and on the site from given storm intervals to an approved point of disposal.
- B. Provide points of connection for stormwater generated by future development upstream.
- C. Prevent the uncontrolled or irresponsible discharge of stormwater onto adjoining public or private property.
- D. Prevent the capacity of downstream channels and storm drainage facilities from being exceeded.
- E. Have sufficient structural strength to resist erosion and all external loads that may be imposed.
- F. Maintain the runoff characteristics of the original undeveloped drainage basin, where feasible, as determined by the City Engineer.
- G. Protect Albany's natural drainage system of streams, lakes, and wetlands.
- H. Maintain or improve overall stormwater quality.
- I. Be designed in a manner to allow economical future maintenance.
- J. Be designed using materials to insure a minimum practical design life of 75 years.
- K. Be consistent with the *Albany Municipal Code (AMC)*, *Albany Development Code*, *Albany Standard Construction Specifications* and all applicable state and federal regulations and requirements for stormwater quantity and quality.

E 1.02 SHORTENED DESIGNATION

These City of Albany *Stormwater Management Engineering Standards* shall be cited routinely in the text as the "Engineering Standards."

E 1.03 APPLICABILITY

These Engineering Standards shall govern construction and upgrading of all public stormwater management facilities in the City of Albany and applicable work within its service areas. These Engineering Standards shall also govern the construction of private stormwater management facilities that require Public Works review.

Permanent stormwater management facilities shall be provided on all property improvements within the City of Albany per these Engineering Standards for the following types of development:

- A. All major partitions and subdivisions.
- B. All public and private development that requires stormwater reviews and/or approvals from the Public Works Department. These Engineering Standards are intended to fulfill the requirements of the “Special Storm Sewers” section of the Oregon Plumbing Specialty Code for private storm drains.
- C. Developments entailing construction that would change the point of discharge of surface waters, the quantity of discharge, or discharge surface waters at a higher velocity or flow than that of the preconstruction discharge rate, or could contribute to pollution of surface waters.
- D. Construction or reconstruction of public roadways and temporary detours.
- E. Developments entailing construction in or adjacent to any existing stream or surface watercourse including intermittent streams.
- F. Developments requiring construction in or adjacent to the 100-yr floodplain of any stream.

E 1.04 REFERENCES

The Engineering Standards are intended to be consistent with the most currently adopted provisions of all stormwater-related guidelines including but not limited to:

- A. *Albany Area Stormwater Management Plans*
- B. *Oregon Statewide Planning Goals and Guidelines*
- C. *Albany Transportation System Plan (TSP)*
- D. *Albany Municipal Code (AMC)*
- E. *Albany Comprehensive Plan*
- F. *Albany Development Code (ADC)*
- G. *Albany Facility Plans*

E 1.05 STANDARD CONSTRUCTION SPECIFICATIONS

Except where the standards provide otherwise, design detail, workmanship, and materials shall be in accordance with the current edition of the *Standard Construction Specifications* prepared by the City of Albany.

E 1.06 DEFINITIONS AND TERMS

- A. City Engineer. The City Engineer of the City of Albany or his/her authorized representative.
- B. Comprehensive Plan. An official document that establishes the future land use patterns and land use polices for the City, as may be currently established by the City Council.
- C. Construction Specifications. A document containing specifications and detail drawings which apply to the construction of all public facilities, private connections to public facilities, and private stormwater treatment facilities.

- D. Creek. Any and all surface water routes generally consisting of a channel having a bed, banks, and/or sides in which surface waters flow in draining from higher to lower land, both perennial and intermittent; the channel, banks, and intervening artificial components, excluding flows that do not persist for more than 24 hours after cessation of 1/2 inch of rainfall in a 24-hr period from October through March.
- E. Definition of Words. Wherever in these standards the words directed, required, permitted, ordered, designated, or words of like importance are used, they shall be understood to mean the direction, requirement, permission, or order of designation of the City Engineer. Similarly, the words approved, acceptable, and satisfactory shall mean approved by, acceptable to, or satisfactory to the City Engineer.
- F. Detention. The release of surface water runoff from a site at a slower rate than it is collected by the drainage system, the difference being held in temporary storage.
- G. Development. Any human made change to improved or unimproved real estate, including but not limited to the addition of buildings or other structures, utility infrastructure, impervious surfaces, other structures or facilities; the activities of mining, dredging, paving, filling, or excavation; or the addition of any surface type that changes or impedes the natural flow of stormwater runoff. Development also includes partitions, subdivisions and redevelopment or modifications to the existing impervious surface footprint on a property.
- H. Development Site. Legally established lots, parcels, or tracts of land involved in a land use application or building/construction permit application. Sites that are occupied or capable of being occupied by a building or group of buildings including accessory structures and accessory uses, together with yards or open spaces, setback areas, and access as required by the *Standard Construction Specifications*.
- I. Discharge. Any addition of water, stormwater, wastewater, process water, or any pollutant or combination of pollutants to waters of the State, directly or indirectly, by actions of dumping, spilling, disposing, or physically connecting to the public storm system or natural drainage conveyance.
- J. Drainage Facilities. Pipes, ditches, detention basins, creeks, culvert bridges, etc., used singularly or in combination with each other for the purpose of conveying or storing runoff.
- K. Easement. A permanent or temporary interest or right to lay down, construct, reconstruct, replace, operate, inspect, and perpetually maintain storm drainage or surface water pipelines, and all related facilities through, under, and along a described property, either public or private.
- L. Erosion. Movement or displacement of soil resulting from natural and human-induced processes including weathering, dissolution, abrasion, corrosion, and transportation.
- M. F.I.R.M. Flood Insurance Rate Maps, which have been developed by the Federal Emergency Management Agency, showing 100-yr, base flood elevations for various creeks and rivers.
- N. Floodway. The limits of the regulatory floodway is the stream channel plus that portion of the overbanks that must be kept free from encroachment in order to discharge the 1-percent-annual-chance flood without increasing flood levels by more than 1.0 foot.
- O. Green Infrastructure (GI). A specific type of stormwater control using vegetation, soils, and natural processes to manage stormwater.
- P. Hazardous Materials. Materials described as hazardous by the Oregon Department of Environmental Quality (DEQ), including any toxic chemicals listed as toxic under Section 307(a) of the Clean Water Act or Section 313 of Title III of the Superfund Amendments and Reauthorization Act (SARA).
- Q. Impervious Surface. An improved, altered, or constructed surface that generally prevents infiltration of surface water. Common impervious surfaces include, but are not limited to: paved streets; graveled or paved areas such as parking lots and driveways, oiled, macadam or other treated surfaces; walkways and patios; roof surfaces; and, heavily-compacted earthen materials designed for vehicular traffic.
- R. Infiltration. The hydrologic process by which water on the ground surface enters the soil.

- S. Infiltration Facility. A stormwater management facility that may be used for water quality or flow control, designed to use the hydrologic process of surface water and stormwater runoff soaking into the ground to dispose of surface water and stormwater runoff.
- T. Infiltration Rate, Design. The infiltration rate measured on site and divided by a Factor of Safety of two.
- U. Infiltration Rate, Measured. The infiltration rate that is measured on site. See Appendix E 10.06 for the approved infiltration testing methods.
- V. Intermittent Streams. Streams and springs that consistently do not have year-round water or saturated soil within their channel or swale in a year with wet to average precipitation patterns. Intermittent flow must occur with some degree of regularity and must be in a definite direction.
- W. Low Impact Development (LID). LID is a stormwater management approach that seeks to mitigate the impacts of increased runoff and stormwater pollution using a set of planning, design and construction approaches and stormwater management practices that promote the use of natural systems for infiltration, evapotranspiration, and/or reuse of rainwater, and can occur at a wide range of landscape scales (i.e., regional, community and site). LID is a comprehensive land planning and engineering design approach to stormwater management with a goal of mimicking the pre-development hydrologic regime of urban and developing watersheds.
- X. Municipal Separate Storm Sewer System (MS4). A conveyance or system of conveyances (including roads with drainage systems, municipal streets, catch basins, curbs, gutters, ditches, man-made channels, or storm drains) as defined in Code of Federal Regulations Title 40 Section 122.26(b)(8).
- Y. National Pollutant Discharge Elimination System (NPDES) Permit. A permit issued pursuant to Chapter 402 of the Clean Water Act (40 CFR 122, 124 and 504).
- Z. Natural Location. The location of those channels, swales, and other non-manmade conveyance systems as defined by the first documented topographic contours existing for the subject property either from maps or photographs.
- AA. Natural Resource Overlay District. An overlay district as defined in the Albany Development Code.
- BB. Onsite. The term “onsite” in these standards when used in reference to stormwater quality facilities is used to describe a subset of facilities located outside the public right-of-way. It is not necessarily a distinction between publicly or privately maintained stormwater facilities (e.g., dry ponds).
- CC. Peak Discharge. The maximum water runoff rate (cfs) determined for the design storm.
- DD. Perennial Streams. Streams and springs that have flowing water year-round during a typical year. The water table is located above the streambed for most of the year. Groundwater is the primary source of water for stream flow; runoff from rainfall is a supplemental source of water for stream flow.
- EE. Plans. Construction plans, including system site plans, storm drain plans and profiles, cross sections, detailed drawings, etc., or reproductions thereof, approved or to be approved by the City Engineer, which show the location, character, dimensions, and details for the work to be done, in which constitute a supplement to these Engineering Standards.
- FF. Post-Construction Stormwater Quality Facility. Permanent stormwater infrastructure incorporated into a development or redevelopment project designed to reduce pollutant loads and runoff velocity from impervious surfaces, and which may also include improvements constructed to reduce the quantity of stormwater runoff leaving the site. Also referred to as “Stormwater Quality Facility” or a “Stormwater Facility” or “Water Quality Facility” and “Infiltration Facility” in this document.
- GG. Pollutant. Any of the following, but not restricted to: oil, grease, soil, mining waste, spoil, solid waste, incinerator residue, sewage, garbage, sewage sludge, munitions, chemical wastes, biological materials, radioactive materials, heat, heavy metals, asbestos, wrecked or discharged equipment, cellar dirt, and untreated industrial, municipal, and agricultural discharges into water.

- HH. Pretreatment or Treatment. The reduction of the amount of pollutants to the maximum extent practicable (MEP), the elimination of pollutants, or the alteration of the nature of pollutant properties in water to a less harmful state.
- II. Private Facility. A facility owned and maintained by a private entity (person, business, etc.), located outside of the public right-of-way.
- JJ. Public Facility. A facility owned and maintained by the City of Albany and located within a dedicated right-of-way, tract, or within a public easement.
- KK. Receiving Bodies of Water. Creeks, streams, lakes, and other bodies of water into which waters are artificially or naturally directed.
- LL. Redevelopment. Any proposed development on a previously developed site that creates or replaces impervious surface. To the extent allowable under federal law, redevelopment does not include: Maintenance Activities; Construction Activities conducted to ameliorate a public health or safety emergency or natural disaster; and/or Construction Activities within an existing footprint to repair or replace a site of a structure damaged by a public health or safety emergency or natural disaster.
- MM. Release Rate. The controlled rate of release of drainage, storm, and runoff water from property, storage pond, runoff detention pond, or other facility during and following a storm event.
- NN. Retention. The process of collecting and holding surface water runoff from a design storm with no surface outflow.
- OO. Right-of-Way (ROW). All land or interest therein which by deed, conveyance, agreement, easement, dedication, usage, or process of law is reserved for or dedicated to the use of the general public within which the City has the right to install and maintain storm drains.
- PP. Riparian. Land adjacent to a water body that directly affects or is affected by the aquatic environment. This includes streams, rivers, and lakes and their side channels, floodplains, and wetlands, and portions of the adjacent slopes that shade the channel or provide streamside habitat.
- QQ. Sedimentation. Disposition of erosional debris-soil sediment displaced by erosion and transported by water from a high elevation to an area of lower gradient where sediments are deposited as a result of slack water.
- RR. Stormwater Quality Facility. Permanent stormwater infrastructure incorporated into a development or redevelopment project designed to reduce pollutant loads and runoff velocity from impervious surfaces, and which may also include improvements constructed to reduce the quantity of stormwater runoff leaving the site.
- SS. Stormwater Management Facilities. Include drainage facilities and post-construction stormwater quality facilities as defined above.
- TT. Stormwater Master Plan. A document adopted by Albany's City Council that describes Albany's existing and planned Trunk Drainage System. The planned drainage system is based on runoff projected for Albany based on Albany's full development under the adopted Comprehensive Plan.
- UU. Subwatershed (MS4). A subdivision of a watershed and is the sixth-level 12-digit unit of the hydrologic unit hierarchy as defined by the National Watershed Boundary Dataset (USGS et al 2013).
- VV. Top of Bank. The ordinary high water level for a water basin or wetland, and the vertical point along a water course where an abrupt change in slope is evident. In the absence of physical evidence, the two-year recurrence interval flood elevation may be used to approximate the bankfull stage or delineate the top-of-bank (OAR 141-085-0510(6)).
- WW. Total Suspended Solids (TSS). TSS refers to waterborne particles determined to be between 2 microns to 125 microns in size per 40 CFR 136.

E 2.00 – STORMWATER PLAN

E 2.01 STORMWATER REPORT AND SITE PLANS

Stormwater site plans, drawn to scale, showing the existing and proposed stormwater systems and other required information must be submitted with a stormwater report for a development. The existing and proposed stormwater site plan must be on separate plan sheets.

The proposed plan must show profile and plan view of the proposed improvements. The stormwater report must include stormwater quality facility sizing forms and calculations, and sizing calculations for stormwater conveyance and detention facilities. Calculations shall clearly show how flows were calculated and also how the proposed storm system is capable of conveying these flows. For projects that require detention, full pre-development and post-development calculations shall be submitted.

E 2.02 EXISTING STORMWATER SITE PLAN

The existing stormwater site plan must include a topographical contour map, drawn to scale, and clearly defining existing conditions along with the elements listed below:

- A. The plan shall clearly show the drainage basins within, and/or contributing to, the improvement limits. Existing routing and discharge locations of the basins shall be shown.
- B. Existing contours of the land at two-foot intervals, or as otherwise required or approved by the City Engineer, with the location of existing buildings, structures, and public and private utilities on the property. Location of any existing building or structure on adjacent property that is within 15 ft of a proposed stormwater facility.
- C. All areas improved or unimproved, lying upstream and draining to, or through the proposed development.
- D. All areas improved or unimproved, lying downstream, of a main line, that will receive the runoff generated from the site.
- E. Location of existing stormwater facilities that transport surface water onto, across, or from the site, including natural watercourses, artificial channels, drain pipes, or culverts.
- F. Location of infiltration testing locations if applicable.
- G. Location of any existing stormwater quality facilities and detention facilities, along with delineation and tabulation of the drainage areas (e.g., number of acres) contributing to each facility.
- H. Location of any septic drain fields and areas of known contaminated soil or groundwater.
- I. Location of springs, wells, or other subsurface water sources.
- J. Arrows indicating drainage direction in all public and private property and for all stormwater conveyance systems.
- K. The route used in determining the pre-developed time of concentration.
- L. Existing structures and impervious surfaces.
- M. Floodplains, the Floodway, protected natural resource areas (protected significant vegetation and protected riparian corridors), hazard overlays, and wetlands.
- N. Infiltration prohibitions and/or restrictions that are known to apply at the site (see Table E 3.02-A).

E 2.03 PROPOSED STORMWATER SITE PLAN

The proposed stormwater facility plan sheets must clearly define the impacts and improvements to the site and include necessary construction details. (The requirements of this section, as applicable, satisfy the requirements for a post-construction stormwater quality plan as identified in Title 12 of the Albany Municipal Code.)

- A. The plan must clearly show the drainage basins within, and/or contributing to, the improvement limits. Proposed routing of all piping and other drainage improvements and discharge locations of the basins must be shown.
- B. Proposed contours of the land after completion of the project at two-foot intervals, or as otherwise required or approved by the City Engineer. This must include elevations, dimensions and location, extent, and slopes of all grading work proposed to be done.
- C. Identify cut and fill areas, soil types, topography, and vegetation.
- D. Location of proposed stormwater facilities that transport surface water across or from the site, including, but not limited to, natural watercourses, artificial channels, conveyance pipes, under drain pipes, and culverts.
- E. Location, type, size, capacity, and details of proposed stormwater quality facilities, detention facilities, impervious area reduction measures (i.e., pervious pavement, green roofs, and tree protection), and excess flow escape routing. Clearly identify all impervious surfaces contributing to each facility along with delineation and tabulation of drainage areas (e.g., number of square feet [ft²]) draining to each facility.
- F. Location of trees to be protected for impervious surface credits.
- G. Planting plans for stormwater quality facilities.
- H. Boundaries and total square footage of all impervious surfaces and areas that will be otherwise altered in a manner that will increase surface water runoff and boundaries of all areas to remain in an existing or natural condition.
- I. The route used in determining the post-developed time of concentration.

E 3.00 – STORMWATER QUALITY

E 3.01 GENERAL REQUIREMENTS

Stormwater quality facilities are encouraged on all new development and redevelopment projects and are required in most situations per Title 12 of the Albany Municipal Code. Publicly maintained stormwater quality facilities, located in the ROW, that treat both water from the public ROW and adjacent private development may be allowed. All City of Albany financed, and/or approved transportation projects shall, to the maximum extent practicable, use approved green infrastructure such as swales, planters, and other engineered vegetated Stormwater Quality Facilities to capture, filter, and/or treat stormwater runoff within the right-of-way, in a manner appropriate to the function and context of the facility. In most instances, facilities not located in the ROW must be privately maintained consistent with the requirements of Title 12 of the Albany Municipal Code and the Private Stormwater Facilities Operations and Maintenance Agreement and Checklists provided in Appendix E 10.04 Operations & Maintenance Agreement and Checklists. Generally, stormwater quality ponds constructed on a separate tract or parcel within a residential subdivision, to serve said subdivision, will be constructed as a public facility and be shown on the plat.

- A. These requirements are established to comply with state and federal water quality and stormwater regulations and the Albany Municipal Code.

- B. The purpose of the stormwater quality standards is to:
- reduce pollutant loads,
 - reduce the velocity and quantity of stormwater runoff, and
 - provide for the infiltration and treatment of stormwater runoff on or as close as possible to the site where it is generated.
- C. Additionally, the goal of these stormwater quality standards is to require, where feasible, infiltration, low impact development, and vegetated stormwater quality facilities (i.e., green infrastructure).

E.3.02 STORMWATER QUALITY GENERAL DESIGN REQUIREMENTS

General design requirements for stormwater quality facilities are provided below.

- A. The City's Water Quality Design Storm is a 1-inch in 24-hour rainfall event. This design storm event represents 80% of the average annual runoff.
- B. Treatment facilities must target removal of 80% of the total suspended solids (TSS) from the captured runoff volume. Removal of TSS is a design surrogate for stormwater quality treatment for various pollutants including the City's regulatory requirements to address mercury and bacteria Total Maximum Daily Loads for the Willamette Basin, per the Oregon Department of Environmental Quality (DEQ).
- C. Stormwater quality facilities listed in Section E 3.03, and designed according to City standards, have been established to meet the stormwater quality performance standards in Section E 3.01.B for the Water Quality Design Storm in Section E 3.02.A.
- D. The City's stormwater quality standards rely on the following order of prioritization for managing the Water Quality Design Storm:
1. Infiltration/Retention (referred to collectively as "infiltration")
 2. Treatment
 3. Off-site mitigation
 4. Fee-in lieu
- E. Prior to proceeding to a lesser priority solution as identified in E.3.02(D), it must be demonstrated to the City's satisfaction and approval, that the higher priority solution is not feasible. In demonstrating that infiltration and/or treatment is not feasible onsite, the applicant must submit written technical justification regarding infeasibility of meeting requirements in the form of a site-specific hydrologic or design analysis conducted and endorsed by an Oregon registered Professional Engineer, or Oregon Certified Engineering Geologist. Grounds for determining infeasibility of meeting the requirements onsite include the following: (note: costs cannot be the sole reason for not meeting requirements onsite.)
1. The requirements will cause harm or a significant threat of harm to public health, safety, and welfare, including water quality or quantity, or harm public or private property.
 2. The requirements cannot be met because an emergency exists, such as where there is immediate danger of landslide, damage to public or private property, or failure of a public facility.
 3. Site topography, site soils, or site contamination issues make it impractical to construct stormwater quality facilities.
- F. Table 3.02-A identifies specific conditions where either infiltration facilities are prohibited, or where all stormwater quality facilities are restricted or prohibited, consistent with the criteria in E.3.02(E.) above.

G. Information to determine the appropriateness of the prioritized management approaches is as follows:

- **Infiltration:** Infiltration testing is required at the proposed stormwater quality facility location unless any one, or more, of the criteria identified in Section E 3.02.E, Nos. 1–3 or Table 3.02-A, have been met at the facility location. Infiltration testing must be conducted according to procedures outlined in Appendix E 10.06. If measured infiltration rates (the rate prior to applying the factor of safety) are greater than or equal to 1.0 inch per hour (in/hr), stormwater quality facilities must be designed for complete infiltration/retention of runoff from the City's Water Quality Design Storm, or infiltration to the greatest extent practicable if constrained by factors identified in Section E 3.02.E or Table 3.02-A. Sites with a measured infiltration rate of less than 1.0 in/hr may not rely on infiltration to manage the Water Quality Design Storm.

Infiltration testing is not required for sites where the USDA NRCS Soil Survey Geographic Database shows that the onsite soils are hydrologic group D or related soils A/D, B/D, or C/D. These soils are known to have infiltration rates that are too low to support sufficient stormwater management through infiltration. If infiltration is desired and the soil maps are believed to be in error, onsite infiltration testing is required prior to allowing infiltration for management of runoff from the Water Quality Design Storm.

- **Treatment:** For the portion of the Water Quality Design Storm that cannot be infiltrated, treatment is required prior to discharging stormwater off-site. In areas where infiltration is not prohibited, treatment facilities must be unlined to promote as much incidental infiltration as possible prior to discharging stormwater off-site. In areas where infiltration is prohibited, treatment facilities must be lined.
- **Off-site Mitigation:** At sites where neither infiltration nor treatment are feasible for managing runoff generated from the Water Quality Design Storm, the remaining runoff volume must be addressed through construction of compensating infiltration or treatment facilities off-site. Off-site mitigation facilities must be constructed in the same subwatershed as the project site at a location identified by, or approved by, the City.

In rare instances where infiltration, treatment, and off-site mitigation are all found to be infeasible, payment of a fee in-lieu of constructing a stormwater quality facility will be required as specified in Albany Municipal Code Title 12.45.040. Collected fees will be dedicated to funding stormwater quality facilities in the same subwatershed as the development.

TABLE 3.02-A: Stormwater Quality Facility Siting Restrictions and Prohibitions

Infiltration is Prohibited (lined facilities required)	Notes
Steep Slopes and Landslide Hazards	Infiltration facilities are prohibited in areas with slopes over 10%, and within a 50-ft buffer from the top and toe of the slope and/or within 200 ft of landslide hazards.
Contaminated Soils	<p>Infiltration facilities are prohibited in areas with known contaminated soils, including a 50-ft setback from parcels with identified active contamination, or at a distance that can be demonstrated to ensure that contaminants will not be mobilized by infiltration from the stormwater facility. Sites that have contaminated soil conditions would need to be evaluated by DEQ and/or the EPA to determine if areas on the property are suitable for infiltration facilities. Potential resources for identifying contaminated sites include but are not limited to the following:</p> <ul style="list-style-type: none"> • DEQ’s Leaking Underground Storage Tank (LUST) database: Oregon DEQ: Land Quality - Tanks - LUST - Search Leaking Underground Storage Tank Cleanup Site Database (state.or.us) • DEQ’s Environmental Cleanup Site Information database: Department of Environmental Quality: Environmental Cleanup Site Information Database: Environmental Cleanup: State of Oregon • DEQ’s Facility Provider Map: Oregon Dept. of Environmental Quality (state.or.us)
Fill Soils	Infiltration facilities are prohibited on fill soils deeper than 5 ft as measured from the highest finish grade adjacent to the proposed facility and the lowest existing grade under the proposed facility. An exception may be made if a stamped geotechnical report indicates suitable stability for an unlined facility.
Seasonal High Ground Water	Infiltration facilities are prohibited in areas with less than 3 ft of separation between the bottom of the facility and the seasonal high groundwater table (SHGT) elevation as determined by a high groundwater investigation as specified in Appendix E 10.06. These groundwater investigations will only be required if all other conditions have been met for the application of an infiltration dependent facility as identified in Section E.3.02.E and in this table. Unless precluded for another reason, treatment facilities that do not rely on infiltration may be allowed in areas of high groundwater as long as the bottom of the facility is above the groundwater.
Adjacent to Domestic Wells	Infiltration facilities are prohibited within a 100-ft buffer around domestic wells to maintain consistency with Oregon Administrative Rules (OAR) protections for public wells.
Stormwater Quality Facilities Restricted or Prohibited	Notes
Regulatory Floodway	Stormwater quality management facilities are prohibited within the identified Floodway
Protected Natural Features	Stormwater quality facilities are allowed on a case-by-case basis in Natural Resource and Natural Hazard Areas as identified in Albany Development Code Article 6 and pending approval from the City Engineer.

E 3.03 FACILITY SELECTION AND LOCATION

The following section presents design guidelines for facility selection and location:

- A. Depending on site conditions and type of development, stormwater quality facilities could be located on private property, in the public ROW, or on a dedicated tract or parcel. In most instances, residential subdivisions (especially those where detention is also required-see Section E 8.00 Stormwater Detention) are likely to find a public dry pond facility, constructed onsite on a dedicated tract or parcel, to be the most advantageous. However, in some instances, public street-side facilities may prove beneficial and are allowed. For industrial, commercial, multi-family, or other large site developments, private onsite facilities of various types are standard and must be incorporated into the site design. Private facilities require that a Private Stormwater Facilities Operations and Maintenance Agreement (See Appendix E 10.04 Operations & Maintenance Agreement and Checklists) is recorded with the property.
- B. There are three categories of stormwater quality facilities that may be designed to meet the Stormwater Quality General Design Requirements in Section E 3.02, although restrictions apply for various site types and circumstances. There is a hierarchy to the selection of facilities with vegetated stormwater quality facilities and dry pond stormwater quality facilities as the highest priority and manufactured facilities as the lowest priority.
 - Vegetated Stormwater Quality Facilities. These facilities are encouraged for use on all projects on private property and in public rights-of-way. Treatment in these facilities is achieved by infiltration into the subsurface, and/or filtration of stormwater through vegetation and growing medium prior to discharge to the municipal storm drainage system. They may be sized using traditional hydrologic routing methods or a simplified sizing factor method as specified in Section E 3.04.
 - Dry Pond Stormwater Quality Facilities. Dry ponds may be used to meet the stormwater quality design requirements or designed as combination facilities to meet both the stormwater quality and detention requirements consistent with Section E 8.00 Stormwater Detention. Water quality is achieved through gravitational processes (settling) and filtration of stormwater through vegetation and growing media. Dry ponds that solely rely on gravitational processes for water quality treatment and do not incorporate filtering of stormwater through vegetation and growing medium may NOT be used to meet the stormwater quality design requirements. Dry pond stormwater quality facilities must use hydrologic routing methods for sizing and there are no simplified sizing factors. Submittal will require a hydrologic and hydraulic analysis.
 - Manufactured Facilities. When vegetated stormwater facilities and dry ponds are shown to be infeasible, manufactured treatment technologies may be approved on a case-by-case basis. These facilities are not typically allowed as publicly owned, operated, or maintained facilities.
- C. Generally, stormwater quality facilities may be located within required site landscaping (such as parking lot islands, open space, and street-side planter strips) consistent with the allowances and limitations of applicable local codes and standards.
- D. There will be situations where alternate treatment facilities may be more appropriate to meet stormwater quality design requirements. The City Engineer may consider alternate facilities such as wet ponds, wetlands, filter strips or biofiltration swales on a case-by-case basis.
- E. Stormwater quality facilities must be sized based on the amount of impervious surface in the contributing drainage area. Impervious area reduction measures may be used, as specified in these standards, to reduce the required capacity and size of the facilities.
- F. To assist in the selection of the most appropriate measures and facilities for a project site, Table 3.03-A lists the approved impervious area reduction measures and stormwater quality facilities and their application for various land uses.

- G. Table 3.03-B lists approved impervious area reduction measures and stormwater quality facilities and their applicability with respect to varying site conditions. A stamped geotechnical report is required if infiltration is proposed on fill.
- H. Table 3.03-C provides minimum setbacks for stormwater quality facilities from property lines, foundations and drainfields. Setbacks are measured from the outer edge of the stormwater facility to the adjacent boundary or structure. Facilities may only be located within these setbacks based on a stamped geotechnical report, and if approved by the City. Additional setbacks from steep slopes, contaminated soils and domestic wells are specified in Table 3.02-A.

TABLE 3.03-A: Stormwater Quality Facility Selection by Land Use					
FACILITY TYPE	PUBLIC RIGHT-OF-WAY	RESIDENTIAL SUBDIVISION	COMMERCIAL INDUSTRIAL MULTI-FAMILY (ONSITE)	INSTITUTIONAL (ONSITE)	PRIVATE STREET
<i>Impervious Area Reduction Measures</i>					
<i>Pervious Pavement</i>			✓	✓	✓
<i>Green Roof</i>			✓	✓	
<i>Tree Protection</i>	✓	✓	✓	✓	✓
<i>Vegetated Stormwater Quality Facilities</i>					
<i>Street-side Planter</i>	✓	✓			✓
<i>Street-side Shallow Swale</i>	✓	✓			✓
<i>Curb Extension Planter/ Pod</i>	✓	✓			✓
<i>Onsite Planter</i>			✓	✓	
<i>Onsite Swale</i>			✓	✓	
<i>Dry Pond Stormwater Quality Facilities</i>					
<i>Dry Pond</i>		✓	✓	✓	
<i>Manufactured Facilities*</i>					
<i>Manufactured Facility</i>			✓	✓	✓
<i>* Manufactured facilities will only be considered when it is shown that vegetated stormwater quality facilities and dry pond stormwater quality facilities are infeasible.</i>					

TABLE 3.03-B: Stormwater Quality Facility Selection by Site Conditions

FACILITY TYPE	ON OR NEXT TO BUILDING	PARKING LOT	LANDSCAPED AREA	FLOODPLAIN	STEEP SLOPE (>10%) or LANDSLIDE HAZARDS	ON FILL (>5 FT DEEP)	CONTAMINATED SOILS
Impervious Area Reduction Measures							
<i>PerVIOUS Pavement</i>		✓		✓ ³		✓ ²	
<i>Green Roof</i>	✓ ¹			✓ ³	✓	✓	✓
<i>Tree Protection</i>		✓	✓	✓	✓		✓
Vegetated Stormwater Quality Facilities							
<i>Street-side Planter</i>			✓	✓ ³	✓ ¹	✓ ¹	✓ ¹
<i>Street-side Shallow Swale</i>			✓	✓ ³	✓ ¹	✓ ¹	✓ ¹
<i>Curb Extension Planter/Pod</i>			✓	✓ ³	✓ ¹	✓ ¹	✓ ¹
<i>Onsite Planter</i>	✓ ¹	✓	✓	✓ ³	✓ ¹	✓ ¹	✓ ¹
<i>Onsite Swale</i>	✓ ¹	✓	✓	✓ ³	✓ ¹	✓ ¹	✓ ¹
Dry Pond Stormwater Quality Facilities							
<i>Dry Pond</i>	✓	✓	✓	✓ ³		✓ ²	✓ ¹
Manufactured Facilities							
<i>Manufactured Facility</i>		✓			✓	✓	✓
¹ Impermeable liner required. May have additional building code requirements for facilities on or adjacent to buildings. Even with liners, the presence of certain contaminants may prohibit installation of stormwater quality facilities. ² Geotechnical report required. ³ Stormwater quality facilities are prohibited in the Floodway portion of the 100-yr floodplain. ADC 6.100. ADC Article 6 may place additional restrictions or requirements on stormwater quality facilities located in the 100-yr floodplain.							

TABLE 3.03-C: Stormwater Minimum Setback Requirements for Private Facilities¹

STORMWATER QUALITY FACILITY TYPE	SETBACK FROM	DISTANCE (FT)
Lined Vegetated Facilities	Foundation	0
Lined Vegetated Facilities	Property Line	0
Lined Dry Ponds ²	Property Line	10
Lined Dry Ponds ²	Foundation	10
Unlined Facilities	Property Line	5
Unlined Facilities	Foundation	10
Unlined Facilities	Upslope from any drain field	100
¹ Additional setbacks from steep slopes, contaminated soils and domestic wells are specified in Table 3.02-A. ² Also applies to publicly owned dry ponds on a separate tract or parcel.		

E 3.04 STORMWATER QUALITY FACILITY SIZING

The following sections provide guidance for sizing stormwater quality facilities.

- A. **Drainage Area Delineations.** The development site should be divided into subcatchment drainage areas, and the required facility sizing determined separately for each area. For onsite planters and onsite swales, the impervious surface area within individual subcatchment areas must be less than 20,000 ft², unless otherwise approved by the City Engineer. Multiple facilities and facility types may be used to meet the Stormwater Quality General Design Requirements (Section E. 3.02).
- B. **Determination of Impervious Area.** One of the first steps in sizing of stormwater quality facilities is to determine the amount of impervious area draining to the facility, as described below.
 - a. Estimating Impervious Area:
 - i. For residential (single detached, duplex, triplex, fourplex, townhouse, cottage cluster) partitions and subdivisions, the impervious area is determined by multiplying the area of developable lots (all phases and parcels) by 60% and adding it to the measured actual impervious area from engineering site plans.
 - ii. For all other development, impervious area is calculated by measuring actual impervious area from engineering site plans.
 - iii. The impervious area used in the sizing of stormwater quality facilities is the total of: new impervious area, including streets and sidewalks, plus replaced and/or re-surfaced impervious area.
 - b. Impervious Area Reduction Measures: The following impervious area reduction measures, outlined in E 3.05 B, are considered to be stormwater quality facilities for the purposes of these standards and require that a Private Stormwater Facilities Operations & Maintenance Agreement (See Appendix E 10.04) is recorded with the property.
 - i. Pervious Pavement: Pervious pavements include full depth pervious asphalt, pervious concrete, permeable pavers, and grid systems. Pervious pavements are 100% pervious for purposes of stormwater quality facility sizing calculations with the exception of pervious pavement inlays or overlays which are considered to be 100% impervious in stormwater quality facility sizing calculations. Pervious pavement may only be considered as an impervious area reduction measure when it is designed without an impermeable liner in accordance with specifications provided in these Engineering Standards.
 - ii. Green Roof: A green roof is a lightweight vegetated roof system with waterproofing material, drainage, growing medium, and specially-selected plants. Green roofs are considered 100% pervious surface for purposes of stormwater quality facility sizing calculations.
 - iii. Tree Protection Credit: Impervious area reduction credits are available for protection of existing trees in certain locations that are adjacent to impervious surfaces. To receive stormwater quality credit, retained trees shall be a minimum 8 inches in diameter as measured at 4.5 feet above mean ground level from the base of the trunk. This credit is for the stormwater management benefits that trees of this size provide, including interception and evaporation of rainfall, reduction and slowing of runoff, and cooling of surfaces that contribute to thermal loading of runoff.
 - 1. Tree credits are not available for required street trees or trees in a Significant Natural Resource Overlay District area.
 - 2. The total tree credit shall not exceed 25 percent of the total gross impervious area.
 - 3. To receive a credit, the existing tree and tree canopy must be on the development site and within 20 feet of new and/or replaced ground level impervious or other

hard surfaces (e.g., driveway or patio) on the development site. Distance from impervious or other hard surfaces is measured from the center of the tree trunk.

4. The retained tree canopy area shall be measured as the area within the tree drip line. A drip line is the line encircling the base of a tree, which is delineated by a vertical line extending from the outer limit of a tree's branch tips down to the ground.
5. Overlapping canopy area of trees are not cumulative and may only be counted once.
6. An arborist report may be required if impervious surface is proposed within the drip line of the existing tree. The arborist report must identify that the tree is likely to survive following construction in order to receive the credit.
7. Impervious area reduction credits are given as a percentage of the existing tree canopy area, or a minimum credit of 100 square feet for evergreen trees, and 50 square feet for deciduous trees, whichever is greater.
 - Evergreen trees: 20 percent of canopy area
 - Deciduous trees: 10 percent of canopy area
8. The existing tree roots, trunk, and canopy shall be fenced and protected during construction activities for all phases of development. Trees shall be maintained and protected on the site after construction and for the life of the development, or until any approved redevelopment occurs in the future. During the life of the development, trees approved for stormwater credit shall not be removed without approval from the City. (In addition to approvals from a stormwater credit perspective, additional approvals for tree felling may be required consistent with the Albany Municipal Code and Albany Development Code.) Trees that are removed or die shall be replaced within six months with like species. Trees may be pruned for safety purposes only; however, if a tree is located near a building, pruning to protect the structure is allowed.

C. Stormwater Quality Facility Sizing by Facility Type:

- a. Facility Sizing for Infiltration (Vegetated Stormwater Quality Facilities and Dry Pond Stormwater Quality Facilities): Guidance for sizing infiltration facilities is provided below.
 - i. Determine drainage basin characteristics:
 1. Area pervious (ac)
 2. Area impervious (ac)
 3. Runoff coefficients or curve numbers (CN) as applicable
 4. Infiltration rates (at the base of the proposed facility)
 5. Depth to the seasonal high groundwater table
 - ii. Through infiltration testing, confirm whether the measured infiltration rate at the base of the facility is 1.0 in/hr or greater. Infiltration testing procedures and requirements are provided in Appendix E 10.06. If the measured infiltration rate is 1.0 in/hr or greater, infiltration of runoff from the Water Quality Design Storm is required. If the measured infiltration rate is less than 1.0 in/hr, then proceed to Section 3.04.C.b to size the facility for water quality treatment.
 - iii. Verify there is at least 3 ft or more of separation between the seasonal high groundwater table (SHGT) and the bottom of the proposed facility. Procedures and requirements are provided in Appendix E 10.06. If the SHGT is within 3 ft of the bottom of the facility, then proceed to Section E 3.04.C.b to size the facility for water quality treatment (note that for facilities not

dependent on infiltration for managing the Water Quality Design Storm the SHGT must be no higher than the base of the facility).

- iv. Proceed with one of the following two methods for sizing the facility(ies):

Method 1 – Sizing Factor Method for Sizing Infiltration Facilities. If the facility(ies) is a vegetated stormwater quality facility (i.e., not a dry pond), and, it is being sized for infiltration of runoff from the Water Quality Design Storm, it may be sized using a sizing factor from Table 3.04-A based on the measured infiltration rate with a factor of safety of 2 applied to obtain a design infiltration rate for the facility location (i.e., divide the measured infiltration rate by 2 to obtain the design infiltration rate). The sizing factor represents the percentage of the development’s impervious area that would be required for the treatment area of the facility(ies). For example, if the development’s impervious area is 10,000 ft², and the sizing factor is 5%, then the required treatment area of the facility(ies) would be 500 ft².

Note: The stormwater quality facility treatment area calculated using the sizing factors is the surface area required at the standard treatment depth (listed in Section E 3.05 Facility Design Criteria) based on the facility dimensions that are specified in these standards. For some facilities (such as with a street-side shallow swale), the total facility surface area will be greater than the treatment area due to additional facility design parameters (i.e., ponding depth and side slopes) as specified in the standard drawings (see example below). Varying facility dimensions and ponding depths from what is specified in this manual will require more detailed evaluations to determine appropriate sizing factors for the respective design.

Example: For a street-side shallow swale with a 2.5 ft bottom width, treating 5,000 ft² of impervious surface, and with a measured infiltration rate of 1.0 in/hr, a sizing factor of 8% applies (note: 0.5 in/hr should be used to select a sizing factor from Table 3.04-A to represent the design infiltration rate after applying a factor of safety of 2). As a result, the surface area at the standard treatment depth (i.e., standard treatment depth of 5”) is 400 ft² (i.e., 8% of 5,000). Given a treatment area width of 4.5 ft after applying side slopes for the standard treatment depth of 5 inches, and a bottom width of 2.5 ft as shown in drawing number 603B, the total surface area of the facility would then need to be 577.8 ft² (i.e., 88.9 ft long times the facility top width of 6.5 ft).

Method 2 – Hydrograph Method for Infiltration Facilities. If a sizing factor is not used to size the infiltration facility, such as for a dry pond, proceed with the following steps to utilize a hydrograph method for sizing the facility.

- Step 1.** Calculate the runoff volume for the Water Quality Design Storm using the NRCS TR-55, NRCS TR-20, or the SBUH Method. Coefficients and curve numbers used in these methods must be consistent with the Oregon Department of Transportation (ODOT) Hydraulics Manual. The use of alternative design flow and storage volume calculation methods may be allowed but requires pre-approval by the City.
- Step 2.** Calculate the stormwater quality facility storage volume by adding the following applicable volumes multiplied where relevant by the porosity:
 - Volume of the ponding depth.
 - Volume of drain rock if applicable. Porosity of 0.40.
- Step 3.** Using a hydrograph method and hydrologic routing, and the measured infiltration rate with a factor of safety applied (i.e., the design infiltration rate) (see Appendix E 10.06), determine whether the facility capacity is sufficient for infiltrating the Water Quality Design Storm runoff volume. Increase the facility size and configuration until the facility volume is sufficient for infiltrating/retaining the runoff from the Water Quality Design Storm.
- Step 4.** Calculate the drawdown time based on the design infiltration rate obtained through infiltration testing with the required safety factor applied to the measured infiltration rate (see Appendix E 10.06 regarding infiltration testing procedures and the applicable factor of safety).
- Step 5.** Confirm the drawdown time meets the minimum requirement of 48 hours or less (i.e., there is no water remaining on the surface of the facility after 48 hours or less). Adjust the surface area while maintaining the minimum facility design criteria (Section E 3.05) until the design drawdown time is achieved. For facilities with side slopes, include freeboard to determine the facility treatment area at the standard treatment depth.
- Step 6.** If the facility(ies) is being proposed as a combined stormwater quality treatment and detention facility, the requirements of Section E 8.00 Stormwater Detention must also be met.

TABLE 3.04-A: Sizing Factors for Infiltration (of the Water Quality Design Storm) Vegetated Stormwater Quality Facilities

FACILITY TYPE	STANDARD TREATMENT DEPTH (in)	FACILITY WIDTH	SIDE SLOPES	Design Infiltration Rate (in/hr) – The measured infiltration rate with a safety factor of 2 applied. ¹										
				0.5	0.6	0.7	0.8	0.9	1	1.1	1.2	1.3	1.4	1.5
				Facility Area Ratio - Sizing Factor										
Onsite Planter	8	Varies	0	5%	4%	4%	4%	3%	3%	3%	3%	3%	3%	3%
Street-side Planter	8	Varies	0	5%	4%	4%	4%	3%	3%	3%	3%	3%	3%	3%
Onsite Swale	8	6 ft top (treatment width), 2 ft bottom	3:1	7%	7%	6%	6%	5%	5%	5%	5%	4%	4%	4%
Street-side Shallow Swale	5	2.5 feet	3:1 adjacent to the street, and 2:1 adjacent to the sidewalk	8%	7%	7%	6%	6%	5%	5%	5%	5%	4%	4%

¹ See Appendix E 10.06 for infiltration testing procedures and factor of safety.

b. Sizing for Water Quality Treatment (Infiltration prohibited or infeasible), in Lined and Unlined Facilities:

- i. When infiltration is not prohibited, but infiltration of runoff from the Water Quality Design Storm is not feasible, water quality treatment with an unlined facility is the next priority in order to promote incidental infiltration. Liners are only appropriate to use where identified in these standards or where otherwise approved by the City Engineer.
- ii. Lined and unlined water quality treatment facilities must be sized to treat the Water Quality Design Storm without taking native soil infiltration rates into account. As a result, facilities are sized to treat runoff from the Water Quality Design Storm through filtration mechanisms. In unlined facilities, this approach allows for the additional incidental benefits associated with infiltration without relying on infiltration for the sizing and design of the facility(ies).
- iii. Proceed with one of the following two methods for sizing the facility(ies):

Method 1 – Sizing Factor Method for Sizing Water Quality Treatment Facilities: If the facility(ies) is a vegetated stormwater quality facility (i.e., not a dry pond), and it is being sized for treatment of runoff from the Water Quality Design Storm, it may be sized using a sizing factor from Table 3.04-B. The sizing factor represents the percentage of the development’s impervious area that would be required for the treatment area of the facility(ies). For example, if the development’s impervious area is 10,000 ft², and the sizing factor is 5%, then the required treatment area of the facility(ies) would be 500 ft² (see note below). The sizing factors are based on the SBUH method and filtering the Water Quality Design Storm through the facility and discharging via the underdrain without overflowing the facility.

These sizing factors may only be used for the City’s standard vegetated stormwater quality facilities, and assume that all other standard design criteria in these standards are met. Where alternate facility designs/types have been approved by the City Engineer, detailed facility specific design calculations, stamped by a professional engineer licensed in the State of Oregon, demonstrating how the Water Quality Design Storm will be treated to the standards in Section E 3.02 is required.

Note: The stormwater quality facility treatment area calculated using the sizing factors is the surface area required at the standard treatment facility depth (i.e., treatment area width) based on the facility dimensions that are specified in these standards. For some facilities (such as with a street-side shallow swale), the total facility surface area will be greater than the treatment area due to additional facility design parameters (i.e., ponding depth and side slopes) as specified in the standard drawings (see example below). Varying facility dimensions and ponding depths from what is specified in this manual will require more detailed evaluations to determine appropriate sizing factors for the respective design.

Example: For a street-side shallow swale treating 5,000 ft² of impervious surface, a sizing factor of 3% applies regardless of infiltration rate. As a result, the surface area at the standard treatment depth is 150 ft². Given a treatment area width of 4.5 ft for a 2.5 ft bottom width as shown in drawing number 603B, the total surface area of the facility would then need to be 216.7 ft² (i.e., 33.3 ft long times the facility top width of 6.5 ft).

Method 2 – Hydrograph Method for Sizing Water Quality Treatment Facilities. If the facility is a dry pond, or vegetated stormwater quality facility(ies) and the sizing factor method (Method 1 and Table 3.04-B) is not used to size the facility(ies), then the hydrograph method must be used to size the facility. The hydrograph method is based on hydrologic routing of the Water Quality Design Storm so that flows from this design event discharge via the underdrain without overflowing the facility. To use Method 2, proceed with the following steps:

- Step 1.** Calculate the runoff volume for the Water Quality Design Storm using the NRCS TR-55, NRCS TR-20, or the SBUH Method. Coefficients and curve numbers used in these methods must be consistent with the Oregon Department of Transportation (ODOT) Hydraulics Manual. The use of alternative design flow and storage volume calculation methods may be allowed but requires pre-approval by the City.
- Step 2.** Calculate the stormwater quality facility storage volume by adding the following applicable volumes multiplied where relevant by the porosity:
- Volume of the ponding depth.
 - Volume of the drain rock. Porosity of 0.40.
- Step 3.** Using a hydrograph method and hydrologic routing, and assuming no infiltration into the underlying soils (or use of a lined facility), determine whether the facility capacity is sufficient for treating the runoff from the Water Quality Design Storm without overflowing the facility (i.e., exceeding the stormwater quality facility storage volume calculated in Step 2.). Assume a 3 in/hr infiltration rate through the soil media and outflow from the facility through the underdrain. Increase the facility size and configuration until the facility volume is sufficient for treating the Water Quality Design Storm runoff without overflowing the facility. For facilities with side slopes, include freeboard to determine the facility treatment area at the standard treatment depth.
- Step 4.** If the facility(ies) is being proposed as a combined treatment and detention facility, the requirements of Section E.8.00 Stormwater Detention must also be met.

TABLE 3.04-B: Vegetated Stormwater Quality Facility Sizing Factors for Treatment-Only Facilities (No reliance on infiltration)		
FACILITY TYPE	SIZING FACTOR	NOTES
<i>Onsite Planter</i>	2%	Surface area of vegetated facility with vertical walls. Standard treatment depth = 8 inches above soil surface.
<i>Street-side Planter</i>	2%	Surface area of vegetated facility with vertical walls. Standard treatment depth = 8 inches above soil surface.
<i>Curb Extension Planter/Pod</i>	2%	Surface area of vegetated facility with vertical walls. Standard treatment depth = 8 inches above soil surface.
<i>Onsite Swale</i>	3%	Treatment area of facility at standard treatment depth of 8 inches, not total surface area of facility. Side slopes 3:1.
<i>Street-side Shallow Swale</i>	3%	Treatment area of facility at standard treatment depth of 5 inches, not total surface area of facility. Side slope 3:1 on street side and 2:1 on sidewalk side.

c. Manufactured Facilities:

Use of manufactured devices for treatment of stormwater runoff must be approved by the City Engineer. The treatment device must be sized according to the manufacturer’s recommendations for treating runoff from the Water Quality Design Storm.

E 3.05 STORMWATER QUALITY FACILITY DESIGN CRITERIA

This section provides design criteria for the City's approved stormwater quality facilities. They have been developed with the intent of providing flexibility to the design engineer in selecting the most appropriate facility for each situation. However, the City may require design modifications for public facilities in order to minimize long-term operation and maintenance (O&M) costs and to accommodate other public needs such as preservation of on-street parking.

- A. Stormwater Quality Criteria by Facility Type. Stormwater quality facilities include vegetated, dry pond, and manufactured facilities. Each facility must be sized appropriately to infiltrate and/or treat the contributing drainage area based on the Stormwater Quality General Design Requirements (Section E 3.02). In addition to the facility descriptions below, construction requirements, standard details, and Water Quality Facility Design Guide Drawings (Appendix E 10.05) for vegetated facilities and dry ponds are included in these standards and in the *Standard Construction Specifications*. Alternative facilities require approval from the City Engineer.

1. Vegetated Stormwater Quality Facilities. Vegetated stormwater quality facilities include the following design types:

- Street-side Planter
- Street-side Shallow Swale
- Curb Extension Planters and Pods
- Onsite Planter
- Onsite Swale

The design guidelines for each type are provided below.

- a. Street-Side Planter. Street-side planters are structural, vertical-walled, landscaped facilities located in the planter strip in a street ROW. They are designed to collect, infiltrate and/or treat stormwater runoff from the street, sidewalk and, possibly, from adjacent properties. These facilities are envisioned more in commercial areas and on non-residential streets; however, their use is also allowed in residential settings.
- i. The street-side planter has a standard treatment depth of 8 inches, inclusive of the 2 inches of freeboard within the depressed curb notch entrance (2-inch elevation difference between standard gutter line elevation at the curb notch entrance and the depressed curb notch). This configuration provides 6 inches of ponding depth plus 2 inches of freeboard depth for clearing check dams and entering outlet structures, while still achieving treatment goals.
 - ii. Facilities are comprised of an 18-inch layer of growing medium over a 3-inch gravel lens on top of a 9-inch layer of drain rock.
 - iii. The soil surface must be level to promote infiltration of stormwater throughout the entire surface of the facility. The elevation of the soil surface must be called out on the construction plans.
 - iv. Check dams may be used to maintain required soil surface elevations while also maintaining facility length on steeper sites.
 - v. For unlined treatment facilities not dependent on infiltration for managing the Water Quality Design Storm, and for lined treatment facilities, a perforated pipe is required in the drain rock along with the surface overflow system to collect stormwater and direct it to the storm drain system. For unlined treatment facilities not dependent on infiltration for managing the Water Quality Design Storm, the bottom of the perforated pipe should be elevated 2.5 inches above the bottom of the facility/drain rock for a 4-inch-diameter underdrain. For lined facilities, the perforated pipe should be placed at the bottom of the drain rock.

- vi. If a lined facility is proposed with less than 3 ft of separation from the seasonal high groundwater table, the liner must be designed to resist buoyant forces.
 - vii. When planters are proposed adjacent to on-street parking, a step-out zone must be provided. “No parking” designations may not be used in lieu of the step-out zone.
 - viii. On streets with a standard-width landscape strip, the addition of a step-out zone will prohibit locating street trees within the facility. Therefore, any street tree requirements will need to be met outside of the facility area.
 - ix. Planter walls over 40 ft in length require special design consideration for a keyed joint.
 - x. Planters must be designed such that the vertical height of walls and vegetation above ground do not interfere with sight distance requirements.
- b. Street-Side Shallow Swale. Street-side shallow swales are landscaped facilities located in the planter strip in a street ROW. They are designed to collect and treat stormwater runoff from the street, sidewalk and, possibly, from adjacent properties. These facilities are envisioned for use in residential subdivisions and other low-traffic-volume settings. The primary advantages to their use in residential subdivisions are the preservation of on-street parking without constructed step-out zones, and they are generally easier to construct than planters. Their use in a location other than a residential subdivision requires the approval of the City Engineer.
- i. Street-side shallow swales installed within Albany’s standard residential street cross-section have a 2.5-foot-wide bottom width with 3H:1V side slopes adjacent to the street and 2H:1V adjacent to the sidewalk. The street-side swale has a standard treatment depth of 5 inches, inclusive of the two inches of freeboard within the depressed curb notch entrance (2-inch elevation difference between standard gutter line elevation at the curb notch entrance and the depressed curb notch). This configuration provides 3 inches of ponding depth plus 2 inches of freeboard depth for clearing check dams and entering outlet structures, while still achieving treatment goals.
 - ii. Facilities are comprised of an 18-inch layer of growing medium over a 3-inch gravel lens on top of a 9-inch layer of drain rock.
 - iii. The soil surface on the bottom of the facility must be level to promote infiltration throughout its entire length. The elevation of the soil surface must be identified on the construction plans.
 - iv. Check dams may be used to maintain soil surface elevations while also maintaining facility length on steeper sites.
 - v. For unlined treatment facilities not depending on infiltration for managing the Water Quality Design Storm, and for lined treatment facilities, a perforated pipe in the drain rock along with the surface overflow system collect stormwater and direct it to the storm drain system. For unlined treatment facilities not dependent on infiltration for managing the Water Quality Design Storm, the bottom of the perforated pipe should be elevated 2.5 inches above the bottom of the facility/drain rock for a 4-inch-diameter underdrain. For lined facilities, the perforated pipe should be placed at the bottom of the drain rock.
 - vi. If a lined facility is proposed with less than 3 ft of separation from the seasonal high groundwater table, the liner must be designed to resist buoyant forces.

- c. Curb Extension Planters and Pods. Curb extension planters are large street-side planters that utilize additional space within the roadway for treatment area rather than relying solely on the space within the landscape strip. They are designed to collect and treat stormwater runoff from the street, sidewalk and, possibly from adjacent properties. These facilities are adaptable to most settings. They can be incorporated into a bulb-out at an intersection or constructed as mid-block extensions. The difference between standard curb extension planters and pods is that pods are smaller in scale and are intended only to supplement other stormwater quality facilities on a project. Pods should only be used in residential settings, on low-traffic-volume roads.
- i. Curb extension planters and pods have a standard treatment depth of 8 inches, inclusive of the two inches of freeboard within the depressed curb notch entrance (2-inch elevation difference between standard gutter line elevation at the curb notch entrance and the depressed curb notch). This configuration provides 6 inches of ponding depth plus 2 inches of freeboard depth for clearing check dams and entering outlet structures, while still achieving treatment goals. Pods may also have a curb-notch exit, and the ponding depth for treatment is set from the lowest curb-notch elevation.
 - ii. Facilities are comprised of an 18-inch layer of growing medium over a 3-inch gravel lens on top of a 9-inch layer of drain rock.
 - iii. The soil surface must be level to promote infiltration throughout its entire length. The elevation of the soil surface must be called out on the construction plans.
 - iv. Check dams may be used to maintain required soil surface elevations while also maintaining facility length on steeper sites.
 - v. For unlined treatment facilities not dependent on infiltration for managing the Water Quality Design Storm, and for lined facilities, a perforated pipe in the drain rock along with the surface overflow system collect stormwater and direct it to the storm drain system. For unlined treatment facilities not dependent on infiltration for managing the Water Quality Design Storm, the bottom of the perforated pipe should be elevated 2.5 inches above the bottom of the facility/drain rock for a 4-inch-diameter underdrain. For lined facilities, the perforated pipe should be placed at the bottom of the facility/drain rock.
 - vi. If a lined facility is proposed with less than 3 ft of separation from the seasonal high groundwater table, the liner must be designed to resist buoyant forces.
 - vii. Hybrid versions of these facilities that have some vertical walls, and some sloped sides (maximum 2.5:1 side slope) will be considered on a case-by-case basis. However, new sizing factors will need to be calculated specific to the proposed facility design.
 - viii. Extensions into the roadway will be as shown in Table 3.05-A.

TABLE 3.05-A: Curb Extension		
STANDARD ROADWAY WIDTH	INTERSECTION BULB-OUT	MID-BLOCK BULB-OUT
<i>28-foot</i>	3-foot	4-foot
<i>30-foot or greater</i>	4-foot	5-foot

- ix. For curb extension planters constructed as part of a bulb-out at the intersection of two local streets, the minimum curb return radii is 20 ft. The minimum radii on all other street intersections must be determined in accordance with Division D of these Engineering Standards. Separation between the nearest driveway and the bulb-out must accommodate the design vehicle.
 - x. The cross slope of the pavement between the centerline of the road and curb and gutter must remain constant and not vary with the incorporation of curb extension planters.
 - xi. Similar to standard curb returns, all curb return data around a curb extension planter or pod must be summarized in a table on the construction plans. The table must show the total length of the return, delta angle, curb radius distance, and stationing and elevations of the beginning, $\frac{1}{4}$ delta, $\frac{1}{2}$ delta, $\frac{3}{4}$ delta, and end of the return.
 - xii. In no instance may the use of curb extension planters or pods on a new street result in a loss of 50% of on-street parking for the block on which they are being installed, when compared to what would otherwise be provided.
 - xiii. Curb extension planter walls over 40 ft in length require special design considerations for a keyed joint.
 - xiv. Curb extension planters must be designed such that the vertical height of walls and vegetation above ground do not interfere with sight distance requirements.
- d. Onsite Planter. Onsite planters are structural, vertical-walled, landscaped facilities that could be located in parking lots, adjacent to buildings and pathways, courtyards, or other site landscaping areas. They are designed to collect stormwater runoff onsite from private property.
- i. Onsite planters must have a level soil surface to promote infiltration throughout the entire surface of the facility. The elevation of the soil surface must be shown on the construction plans.
 - ii. Check dams may be used to maintain soil surface elevations while also maintaining facility length on steeper sites. The onsite planter has a standard 6-inch ponding depth in the vegetation zone plus a minimum of 2 inches freeboard that provides for overflows over check dams and flows to outlet structures (creating an 8-inch standard treatment depth).
 - iii. Facilities are comprised of an 18-inch layer of growing medium over a 3-inch gravel lens on top of a 9-inch layer of drain rock.
 - iv. For unlined treatment facilities not dependent on infiltration for managing the Water Quality Design Storm, and for lined facilities, a perforated pipe in the drain rock along with the surface overflow system collect stormwater and direct it to the storm drain system. For unlined treatment facilities not dependent on infiltration for managing the Water Quality Design Storm, the bottom of the perforated pipe should be elevated 2.5 inches above the bottom of the facility/drain rock for a 4-inch-diameter underdrain. For lined facilities, the perforated pipe should be placed at the bottom of the facility/drain rock.
 - v. If a lined facility is proposed with less than 3 ft of separation from seasonal high groundwater, the liner must be designed to resist buoyant forces.
 - vi. See Appendix E 10.05 Water Quality Facility Design Guide Drawings for additional design requirements for onsite planters.
 - vii. When planters are proposed adjacent to the passenger or driver side of a parking stall, a step-out zone must be provided

- viii. When walkways are proposed adjacent to onsite planters, the vertical distance between the walkway and the designed soil surface must be minimized. Structural protective measures, such as curbing, must be incorporated into the design to physically separate pedestrians from the facility.
 - ix. Onsite planters must be designed such that the vertical height of walls and vegetation above ground do not interfere with sight distance/line of sight requirements.
 - x. Planter walls over 40 ft in length require special design consideration for a keyed joint.
 - xi. In general, street-side planter design requirements will be used as a guide for reviewing similar components of proposed onsite planter designs.
 - xii. The maximum amount of impervious surface draining to each onsite planter is 20,000 ft². Multiple facilities can be used to meet treatment requirements.
 - xiii. Careful consideration must be given to the overflow design. These facilities are only intended to handle the Water Quality Design Storm. It is the design engineer's responsibility to ensure larger storm events are also appropriately considered in the site design.
 - xiv. Since these facilities will be constructed on private property, land use approvals and building permits may be required.
 - xv. All vehicular and pedestrian safety (including Americans with Disabilities [ADA]) requirements must be incorporated into onsite designs. It is the property owner and design engineer's responsibility to ensure these requirements are met. Public Works review of private facility design is limited to stormwater quality functions.
- e. Onsite Swale. Onsite swales are shallow, vegetated depressions with side slopes (maximum 3H:1V) and a 2-foot-wide bottom that is flat, with no grade. The elevation of the soil surface must be shown on the construction plans.
- i. Check dams may be used to maintain soil surface elevations while also maintaining facility length on steeper sites. Swales may be located in parking lots and other site landscaping areas. They are designed to collect stormwater runoff onsite from private property.
 - ii. The onsite swale has a standard 6-inch-ponding depth in the vegetation zone plus a minimum of 2 inches freeboard that provides for overflows over check dams and flows to outlet structures (creating an 8-inch standard treatment depth).
 - iii. Facilities are comprised of an 18-inch layer of growing medium over a 3-inch gravel lens on top of a 9-inch layer of drain rock.
 - iv. For unlined treatment facilities not dependent on infiltration for managing the Water Quality Design Storm, and for lined facilities, a perforated pipe in the drain rock along with the surface overflow system collect stormwater and direct it to the storm drain system. For unlined treatment facilities that are not dependent on infiltration for managing the Water Quality Design Storm, the bottom of the perforated pipe should be elevated 2.5 inches above the bottom of the facility/drain rock for a 4-inch-diameter underdrain. For lined facilities, the perforated pipe should be placed at the bottom of the drain rock.
 - v. If a lined facility is proposed with less than 3 ft of separation from seasonal high groundwater, the liner must be designed to resist buoyant forces.

- vi. See Appendix E for additional design requirements for onsite swales. Sizing factors for onsite swales are based on 3H:1V side slopes, a 2-ft bottom width, and an 8-inch treatment depth. Any variation from these standards will require calculation of a facility specific sizing factor.
 - vii. If walkways are proposed adjacent to these facilities, the design engineer will need to consider whether additional measures are required, such as curbing, to separate the walkway from the side slope on the stormwater quality facility. When parking is proposed adjacent to these facilities, curbing or wheel stops are required.
 - viii. The maximum amount of impervious surface draining to each onsite swale is 20,000 ft². Multiple facilities can be used to meet treatment requirements.
 - ix. Careful consideration must be given to the overflow design. These facilities are only intended to handle the Water Quality Design Storm. It is the design engineer's responsibility to ensure larger storm events are also appropriately considered in the site design.
 - x. Since these facilities will be constructed on private property, land use approvals and building permits may be required.
 - xi. All vehicular and pedestrian safety (including ADA) requirements must be incorporated into onsite designs. It is the property owner and design engineer's responsibility to ensure these requirements are met. Public Works review of private facility design is limited to stormwater quality functions.
2. Dry Ponds. Sizing of dry ponds is based on hydrologic routing of the Water Quality Design Storm. Sizing factors, such as those provided for Vegetated Water Quality Facilities, are not appropriate for ponds due to variations in design parameters. When used to meet both the stormwater quality and detention requirements, dry ponds must also meet applicable flow control requirements as described in Section E 8.00 Stormwater Detention.
- a. Dry ponds are designed to fill during storm events and either infiltrate, or slowly release the Water Quality Design Storm volume through an underdrain system after filtering through soil media. When constructed to also serve as detention, volumes greater than the water quality storm volume are routed through an outlet control structure.
 - b. Dry ponds are divided into two cells: a forebay cell and a treatment cell. A pre-treatment manhole is required ahead of the forebay. The pretreatment manhole and the forebay cell serve to extend the life and efficiency of the treatment cell by removing readily settleable debris and floatable debris and oils.
 - c. The inlet to the pond must extend from the pretreatment manhole to the forebay cell with the invert elevation at the outfall located above the sediment storage elevation. Outlet protection must be provided.
 - d. The forebay should contain approximately 10% of the design surface area and provide a minimum 6-inch depth of dead storage for sediment accumulation. Dead storage volume may not be included in design as available storage for treatment or detention volumes.
 - e. Both the forebay and treatment cell bottoms are comprised of an 18-inch layer of growing medium over a 3-inch gravel lens layer and 12 inches of drain rock. The growing medium, but not the rock, must also be placed on the side slopes of the facility extending up to the water quality event design surface elevation. On the facility side slopes above the water quality design surface elevation, 12 inches of topsoil must be placed up to the top of the bank, and beyond to the extent necessary to support required/proposed plantings.
 - f. A rock energy dissipater must separate the forebay from the treatment cell. The top of the rock energy dissipater must be set at 12 inches below the Water Quality Design Storm water surface and have maximum side slopes of 2H:1V. The energy dissipater must be

designed using published references such as Hydraulic Design of Energy Dissipaters for Culverts and Channels published by the Federal Highway Administration or the ODOT Hydraulics Manual. The design reference must be cited on the construction plan submittal. The energy dissipater must be designed to be stable for all anticipated hydraulic conditions. The energy dissipater rock gradation must be sufficient to allow for minimum head differential between the forebay and the treatment cell during the draining cycle of the pond while also allowing for deposition and retention of larger sediment to the forebay.

- g. For unlined facilities not dependent on infiltration for managing the Water Quality Design Storm, and for lined facilities, a perforated pipe in the drain rock along with the surface overflow system collect stormwater and direct it to the storm drain system. The design must assume a 3-inch-per-hour infiltration rate through the growing medium. The required number and spacing of drain pipe must be designed assuming no infiltration is occurring into native soils such that the underdrain system is the primary means of conveyance for the water quality storm. For unlined facilities not dependent on infiltration for managing the Water Quality Design Storm, the bottom of the perforated pipe should be elevated 2.5 inches above the bottom of the facility/drain rock. For lined facilities, the perforated pipe should be placed at the bottom of the drain rock.
- h. If a lined facility is proposed with less than 3 ft of separation from seasonal high groundwater, the liner must be designed to resist buoyant forces.
- i. Underdrain systems may not be used for facilities that depend on infiltration for managing the Water Quality Design Storm or be used to meet detention requirements beyond the Water Quality Design Storm.
- j. Underdrain systems can have many different configurations; pipe sizing and lateral spacing must be based on facility size and individual site conditions subject to the following minimum requirements:
 - i. Minimum perforated pipe size is 4-inch-diameter.
 - ii. Underdrain laterals can be no more than 10-foot-on-center-spacing; at minimum provide one underdrain for every 1,000 ft² of surface area.
 - iii. Include at least two cleanouts for each underdrain lateral, one at the upstream end and one at the downstream end.
 - iv. Piping must conform to the requirements of the Uniform Plumbing Code.
- k. The soil surface on the bottom of the facility must be generally level to promote infiltration of stormwater throughout the entire length of the facility. The elevation of the soil surface must be identified on the construction plans.
- l. The minimum freeboard in ponds is 1-ft above the emergency overflow structure or spillway elevation.
- m. Dry ponds may have a maximum water depth of 4 ft. The minimum width at the bottom of the pond is 4 ft. The width of the pond must vary by 4 ft at a minimum of two separate points to produce a more natural pond shape.
- n. Side slopes for dry ponds should not exceed a slope of 3H:1V. Moderately undulating slopes are acceptable and can provide a more natural setting for the facility. Gentle side slopes improve the aesthetic attributes of the facility and enhance safety.
 - i. For public facilities, interior sides slopes must be no steeper than 3H:1V, even if fenced, to minimize safety risks. Access to the side slopes must be provided for maintenance. For private facilities, the same is recommended rather than required.

- ii. Exterior side slopes for public or private facilities may not be steeper than 2H:1V unless confirmed stable by a geotechnical engineer.
- iii. The maximum water depth of any pond is 4 ft.

See Section E 8.00 Stormwater Detention, Appendix E 10.05 Design Guide Drawings, and related *Standard Construction Specifications* for additional design requirements for dry ponds.

3. Manufactured Facilities. Manufactured facilities must be approved by the City Engineer. The treatment device must be designed and installed per the manufacturer's recommendations. Since these facilities may be constructed on private property, land use approvals and building permits may be required.

B. Impervious Area Reduction Measures.

1. Pervious Pavement. Pervious pavements include pervious asphalt and concrete, permeable pavers including various modular pre-cast units, and concrete or plastic grid systems that are filled with soil/vegetation or permeable aggregate. Full depth pervious pavement does not contribute to a site's total impervious area. Pervious paving is an impervious area reduction measure only, and not a stormwater quality facility designed to receive runoff from adjacent areas. However, it is still part of the Post-Construction Stormwater Quality (PCSWQ) program and will require an O&M agreement (Appendix E 10.04) to ensure it is maintained over time. Design site grading to slope adjacent impervious and pervious areas away from pervious pavement to the maximum extent practicable. Pervious pavement may not be used on slopes greater than 6%.

Pervious pavements must be designed to provide a minimum initial infiltration rate through the pavement or pavers of 20 in/hr. The soils at the base of the facility must have a design infiltration rate of 0.5 in/hr or greater. If soil infiltration rates at the base of the facility are less than 0.5 in/hr, the design must include a perforated pipe underdrain system, centered vertically in the reservoir course (drain rock) layer. Minimum perforated pipe size is 4-inch-diameter. The underdrain perforations or slots shall only be located on the lower half of the pipe. Pipe sizing and lateral spacing must be based on pervious pavement size and individual site conditions. Emergency overflow or inlets must be provided to avoid flooding in case surface becomes plugged.

Minimum design criteria for pervious pavements for use on parking lots and vehicular travel ways are listed below. It is the responsibility of the design engineer to propose materials and sections that are appropriate for anticipated loadings and turning movements, and to locate pervious pavement in appropriate locations given individual site conditions.

Permeable pavers and grid systems may not be used within vehicular travel ways, over public utilities, or in the public ROW.

- a. Pervious Asphalt. Pervious asphalt must have a minimum 1.5-inch thick, 3/8 inch open-graded asphalt wearing surface, and a minimum 2.5-inch thick asphalt treated permeable base (ATPB) layer. Additional ATPB can count towards crushed aggregate reservoir course depth. Use PG70-22 asphalt binder for wearing surface and ATPB. Mix design requires approval from the City Engineer.
 - 10 inches minimum crushed aggregate reservoir course. AASHTO No. 2 open-graded crushed rock (2.5 inches – 1.5 inches) or approved equal with 40% void space. (Reservoir course depth may be increased and used for stormwater detention with approval of the City Engineer.)
 - Place non-woven geotextile over uncompacted subgrade.

- b. Pervious Concrete. Pervious concrete pavement must be a minimum of 6 inch thick open-graded concrete. Mix design requires approval from the City Engineer.
 - 12 inches minimum crushed aggregate reservoir course, AASHTO No. 2 open-graded crushed rock (2.5 inches – 1.5 inches) or approved equal with 40% void space. (Reservoir course depth may be increased and used for stormwater detention with approval of the City Engineer.)
 - Place non-woven geotextile over uncompacted subgrade.
- c. Permeable Pavers. Pavers must meet ASTM C936, Standard Specifications for Interlocking Concrete. Paver systems must be installed per manufacturer's recommendations with open surface spaces between ½ inch and 1 inch.
 - 10-inches minimum crushed aggregate reservoir course, AASHTO No. 2 open-graded crushed rock (2.5 inches – 1.5 inches) or approved equal with 40% void space. (Reservoir course depth may be increased and used for stormwater detention with approval of the City Engineer.)
 - Place non-woven geotextile over uncompacted subgrade.
 - Install edge restraints that are a minimum of 6 inches wide and 12 inches deep along the perimeter of pavers.

See Appendix E 10.05 *Design Guide Drawings* for additional design requirements for pervious pavement.

2. Green Roof. Depending on the configuration and structure of the roof, a vegetated green roof can be constructed to reduce a site's total impervious area. A vegetated green roof is an impervious area reduction measure only and may not receive runoff from adjacent areas. However, it is still part of the PCSWQ program and will require an O&M agreement (Appendix E 10.04) to ensure it is maintained over time. The structural roof support must be designed to accommodate the weight of the vegetated green roof. The green roof design must be low maintenance. Use of irrigation is allowed only to sustain the health of the vegetation. Design of the vegetated green roof must be per the most current standards of the City of Portland, Bureau of Environmental Services' Stormwater Management Manual. Green roofs also require building permit review and approval.

C. Inlets, Outlets, and Overflows

1. Curb Notches. The station and invert elevation of each curb notch must be identified on the construction plans. Curb notches must be spaced to assure that flow along the gutter line can be intercepted by stormwater quality facilities during the Water Quality Design Storm. Curb notches are typically located at the upstream end of each facility, or cell, within a multi-cell facility that is divided by check dams. However, the maximum length between curb notches is 30 ft on a single cell facility, or within the same cell on a multi-cell facility. If a facility or cell has more than one curb notch serving it, the elevations of each notch must be set such that the anticipated treatment (ponding) depth within the facility will not short-circuit. Deviations in the maximum elevation between the curb/sidewalk and the soil surface to accommodate additional curb notches requires the approval of the City Engineer.

In some instances, it may be desirable to also place a curb notch at the downstream end of the last facility along a block length in order to capture and treat all of the water along the project. These instances will require similar reviews and approvals for elevation changes as described in the preceding paragraph.

2. Sidewalk Drainage Notch. 4-inch sidewalk drainage notches must be placed in the exposure of planter walls (planters, pods, and extensions) adjacent to the sidewalk to assure that the flow from sidewalk can be intercepted and ponding on the sidewalk does not occur during the design storm event. Notches are typically centered on sidewalk panel joints every 10 to 15 ft, or one per cell of a multi-cell facility, but in no case may the spacing exceed 20 ft.
3. Sediment Traps. Some locations within the public ROW have higher sediment loads than others. High sediment load areas can be problematic for stormwater quality facilities by “clogging” the soils and reducing overall infiltration. This results in increased maintenance costs and a reduced service life for the facility. To avoid this situation, sediment traps can be incorporated into the inlet design. Sediment traps may be required by the City Engineer in the following locations:
 - a. Facilities on high traffic-volume streets (arterials and collectors).
 - b. Facilities adjacent to, or immediately downstream of, unimproved roads or lots.
 - c. Facilities located in, or immediately downstream of hazard areas (e.g., slopes greater than 10%), or immediately downstream of the Hillside Development Overlay district as shown in the Albany Development Code.
 - d. Other locations identified by the City Engineer as having a potential for high sediment loads.
4. Roof Drains. Roof drains should connect to the street at the standard weep hole located at the curb and gutter. Locations of connections must be shown on the construction plans. Direct connection of roof drains to vegetated stormwater quality facilities and ponds is discouraged and requires approval from the City Engineer.
5. Pretreatment Manholes. Dry ponds, and any other larger, regional water quality facilities, require a pretreatment manhole. Pretreatment manholes have a deeper sump and an outlet ‘tee’ for oils. These structures are intended to provide partial solids retention prior to conveying stormwater to the pond. The pretreatment water quality manhole is not intended to meet other agency requirements for TSS removal. See additional requirements in the City’s *Standard Construction Specifications* and these Standards.
6. Underdrain System. The primary outlet for unlined facilities that are not dependent on infiltration, and lined stormwater quality facilities, is through the underdrain system. Flow is collected in the underdrain system and routed to the stormwater collection system. Methods of connection include:
 - a. Connection to an adjacent curb inlet.
 - b. Stormwater lateral connection to standard piped stormwater system.
 - c. Connection to the underdrain system on an adjacent facility may be considered when two facilities are located on the same side of the street and separated by a short distance, such as a driveway width. The purpose of such a connection would be to reduce, or eliminate, the use of stormwater laterals. When connecting to adjacent facilities the ability of the underdrain system to accept the additional flow must be verified.
 - d. Invert elevations and stationing must be shown for all points of connection.
7. Overflows. All stormwater quality facility designs must incorporate an overflow system in the event the facility temporarily fails or rainfall exceeds the design storm. The overflow system must be designed to maintain public safety and avoid property damage. Overflow elevations must be identified on the construction plans.
 - a. Street-Side Facilities. For facilities with underdrains, a small overflow must be incorporated into the cleanout at the downstream end of the facility. The overflow

must be fitted with an atrium grate sized to the pipe to protect the perforated drain pipe system from debris and sediment. This overflow will supplement the primary overflow, which is also the inlet on most street-side facilities. Larger overflow structures will be required when escape/overflow to the street and a standard stormwater collection/conveyance system is not feasible. For facilities without underdrains, an overflow is required when escape/overflow to the street and a standard stormwater collection/conveyance system is not feasible. In these situations, the type/size of overflow structure and point of discharge require City approval.

- b. Onsite Facilities. Overflow systems may include overflow structures similar to street-side facilities and/or, when approved, storage in parking lots or landscaping areas. Flow routing must be identified on the construction plans to illustrate where flood conditions or ponding is expected to occur during larger rain events.
- c. Dry Pond Facilities. An overflow structure must be provided as either a grated inlet or atrium grate set just above the maximum water surface elevation of the Water Quality Design Storm. If the dry pond is also intended to serve detention requirements, then the overflow water surface elevations will vary with the coinciding water surface elevation for the respective storm events. Design criteria for detention is provided in Section E 8.00 Stormwater Detention.

In addition, an emergency overflow spillway or structure is required for all ponds. The emergency overflow spillway or structure must be designed to accommodate the potential inflow to the facility up to the 100-yr storm event. The overflow must be sited to protect the structural integrity of the facility and be designed to convey/direct flows into downstream conveyance systems. The emergency overflow spillway must be armored with riprap or other flow-resistant material that will protect the embankment and minimize erosion. Minimum freeboard is one foot above the emergency overflow structure or spillway elevation.

D. Cleanouts and Laterals. Stormwater cleanouts and laterals must conform with all requirements outlined in these Standards and the City of Albany Engineering Standards, Division C as applicable.

E. Liners.

1. Impermeable liners are required for specific site conditions as specified in Tables 3.02-A, 3.03-B, and 3.03-C where infiltration facilities are prohibited. Liners must conform with requirements as outlined in the *Standard Construction Specifications*.
2. Impermeable liners must be shown on the construction plans and be constructed to underlay all areas of the facility that are at or below the overflow elevation for the Water Quality Design Storm.
3. For lined facilities, perforated underdrain pipes must be located at the bottom of the drain rock and above the impermeable liner.

F. Anti-seepage Collar. If pipe is constructed in an embankment section, an anti-seepage collar must be provided consisting of 3,000 PSI concrete or bentonite plug around the outside of the inlet/outlet pipe. Concrete or bentonite must be poured against undisturbed soil at a 6-inch minimum thickness on all sides of the pipe. Backfill trench per current City pipe zone and bedding details.

G. Check Dams. Check dams must be used to create multi-cell facilities when street slope and facility length prevents having one continuous facility with a flat soil surface in all directions. Check dams may similarly be used for onsite planters and swales as needed to accommodate site slope and grading conditions.

1. Provide elevations and stationing and/or dimensioning for check dam locations.
2. In a standard installation, each cell will have a curb-notch inlet at the upper end of each cell and a check dam at the lower end of the cell (except for the final cell). The check dam elevation

for each cell must be set at the same elevation as the lowest elevation of the depressed opening for the curb-notch inlet contributing to that cell. The City's *Standard Construction Specifications* provide a drawing depicting the vertical relationship between inlets and check dams for multi-cell facilities.

3. Check dam elevations may not cause stormwater to overflow to the sidewalk.
4. Table 3.05-B provides check dam spacing requirements by street slope. Spacing is based on providing 4 inches of clearance between top of each check dam and the top face of curb.

TABLE 3.05-B: Check Dam Spacing	
STREET SLOPE (%)	ON CENTER SPACING (FT)
1	35
2	19
3	13
4	11
5	9
6	8
>6	Too steep for continuous linear stormwater quality facilities

H. Utility Crossings.

1. General:

- a. Utility crossings under street-side, stormwater quality facilities are discouraged and only allowed on a case-by-case basis.
- b. When crossings are necessary, 1 ft of clearance must be provided between the bottom of the stormwater quality facility and the crossing utility.

2. Water Services:

- a. Water services should cross a standard landscape strip section whenever possible. When that is not possible, services should be placed in the driveway rather than under a stormwater quality facility.
- b. Water service lines may be located no closer to curb extensions than the point of tangency.

I. Hydrant Clearance. No hydrant may be placed closer than 5 ft to a stormwater quality facility.

J. Relationship to Street Cross Slope. The integration of street-side, stormwater quality facilities in the ROW may not change the underlying street cross slopes, including those between the sidewalk and the top face of curb.

K. Sidewalk Location. The sidewalk is typically positioned within the ROW such that there is a 6-inch space between the back of sidewalk and the adjacent property line. Several of the post construction stormwater quality facilities are of such a width that they push the sidewalk 6 inches closer to the property line; therefore, the back of walk is coincident with the property line. The sidewalk should be in a consistent location on a block-by-block basis. Within a given block, the sidewalk should not transition locations as it transitions in and out of being adjacent to facilities.

- L. Sidewalk Timing of Construction. Generally, sidewalk construction cannot be deferred on projects involving construction of stormwater quality facilities in areas such as planter strips where the sidewalk is required to maintain the form of the facility or future construction of the sidewalk is anticipated to result in direct, or indirect, damage to the facility. Although the size and location of driveways must be identified on the construction plans, the City Engineer may allow deferral of driveway construction until construction of other onsite improvements.
- M. Pond Fences. Fences for pond facilities may be required by the City Engineer and should be anticipated to be a requirement if any variations to maximum pool depth or vertical walls are approved. When required, fence standards including; location, height, material, gates, and locking mechanisms, will be set by the City Engineer.
- N. Pond Walls. In response to site constraints, walls may be approved by the City Engineer on a case-by-case basis. Walls will not be allowed within the treatment areas of stormwater quality facilities. Other conditions will be site specific as determined by the City Engineer. Walls that are 4 ft or higher, or periodically inundated, must be designed by a licensed engineer, and may require building permits.
- O. Maintenance Access for Ponds. Access roads must be provided for maintenance of all stormwater quality ponds. The following criteria apply:
 1. Access road must be paved a minimum distance of 20 ft back from public ROW meeting minimum requirements in the Albany Development Code.
 2. Strengthened sidewalk sections must be used where maintenance vehicles will cross.
 3. Maximum longitudinal grade is 12% with a maximum 4% cross-slope.
 4. Minimum width is 12 ft.
 5. All access roads must be constructed with a minimum of 12 inches of 100% fractured-face crushed aggregate base placed on a geotextile subgrade fabric.
 6. Access must extend to within 10 ft of the center of the pretreatment manhole and primary outlet and flow control structures.
 7. The City may require a curb or other delineator at the edge of the road for drainage, a curb stop, or to demarcate the road where the road edge is not apparent.
 8. The side slope for road embankments must be 2H:1V or flatter.
 9. A vehicle turnaround must be provided when the access road exceeds 40 ft in length.
 10. The access road must provide direct connections to any pond access ramps.

For privately owned and operated facilities, the above criteria are considered design guidelines; alternate site specific designs are acceptable.
- P. Pond Signage. The City may require that ponds with high public exposure have signage. Signage requirements will be determined during plan review.

E 3.06 LANDSCAPE REQUIREMENTS

- A. Applicability. The main purpose of vegetation in stormwater quality facilities is to provide the maximum amount of water quality benefit for stormwater management. This section addresses the landscape requirements that apply to the design (planting plans) of stormwater quality facilities with vegetation in the City of Albany. Planting plans are an important mechanism to ensure the proper selection and installation of vegetation in these facilities. The objectives of these standards are:
 1. Providing adequate plant coverage.
 2. Providing information on placing plants in the proper location per varying context factors.

3. Encouraging plant diversity.
 4. Maintaining some year-round foliage.
 5. Defining how to maintain clear lines of sight/access.
 6. Accommodating tree/street tree requirements.
- B. **Moisture Zones.** Careful consideration of the soil moisture conditions within a stormwater quality facility will help to ensure the success of a planting design. Planting conditions for stormwater quality facilities with side slopes have a variety of moisture levels from dry to wet. Soil conditions at and near the bottom of the facility can be wet due to frequent or constant inundation, and side slopes vary from wet at the bottom to relatively dry near the top. The moisture gradient varies with the designed maximum water depth, the time it takes for a facility to drain after a storm event, and the steepness of the side slopes. The zone from the bottom of the facility to the designed high-water line (the designed treatment area or storage areas for ponds) should be planted with plants that tolerate occasional standing water and wet-to-moist conditions. Above the designed high-water line, vegetation is not affected by stormwater entering the facility and should be planted with species well-suited to the local climate and site-specific conditions (i.e., solar aspect, microclimate, etc.). Planting conditions are more uniform for vertical-walled planters because of the relatively uniform and flat surface.

Vegetation for vegetated stormwater quality facilities is categorized according to the degree of soil moisture that will be encountered in the facility during the growing season. Consideration of these zones will enhance the success of a facility's planting design. See Figure E 3.06-A. The figure depicts two different zones:

- Moist (Zone A): periodically saturated; anaerobic and/or aerobic soils
- Dry (Zones B): infrequent inundation/saturation, if any; aerobic soils

Zone B plantings are appropriate in the detention area in combined detention and water quality ponds as long as they are outside the treatment area.

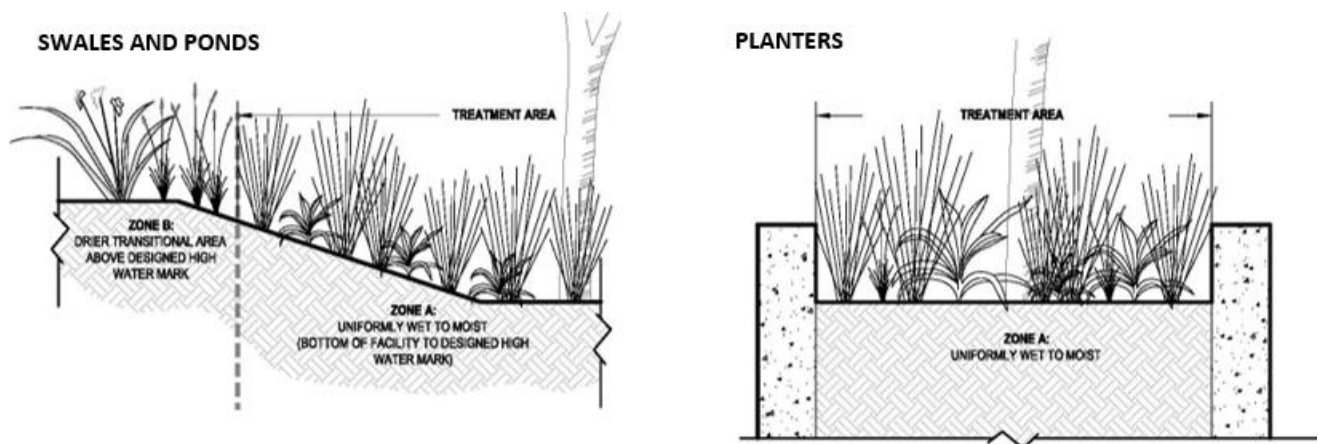

Figure E 3.06-A Planting Zones by Facility Type

- C. **Planting Plan Requirements.** Planting plans are required for design and construction of stormwater quality facilities. At a minimum, planting plans must provide the following:
- Scaled planting plan sheets identifying the location of the facilities within the project limits with call-outs to applicable planting diagrams and tables.
 - A dimensioned planting diagram for each facility with each plant type assigned its own symbol. See Appendix E 10.03 Planting Matrix & Example Planting Diagrams for guidance.

- Planting table that identifies quantities and documents the common name, scientific name, category (herbaceous, small shrub, etc.), distribution (zone and spacing), condition (container, B&B, etc.) and size of planting for each facility. Quantities must be based on the typical on-center spacing (which is the maximum spacing) listed on the plant matrices.
 - Planting legend.
 - Installation methods for plant materials.
 - Recommended long-term irrigation plan, including identification of water source and maintenance of the system, if applicable.
 - Any additional recommendations beyond what is already required in Albany’s *Standard Construction Specifications* for irrigation, weeding, and pruning during the establishment/warranty period.
 - References to applicable portions of Albany’s *Standard Construction Specifications* for growing medium, drain rock, surface treatments, vegetation, timing for plantings, and installation requirements.
- D. Plant Selection. The City’s approved plant lists are provided in Appendix E 10.03 Planting Matrix & Example Planting Diagrams by facility type. Each planting list includes a suitability matrix for limiting contextual factors (such as location and width of facility) as well as a listing of specific characteristics for each species, such as an indication of the appropriate moisture zone, if it is native to the area, if it is evergreen, its average height and a recommended on-center spacing. **These plant matrices provide a short list of plants that are appropriate for the stormwater quality facilities in a variety of conditions. Other plants may be approved if they meet applicable criteria for type/width of facility, condition, location, size of plant material at maturity, etc.**
- E. Landscape Design Requirements:
1. Quantities. Plant quantities are identified below. Plant spacing guidance is provided in planting matrices in Appendix E 10.03 Planting Matrix & Example Planting Diagrams.
 - a. Street-side Facilities:
 - Six small shrubs/100 ft²
 - The remainder of the area must be planted with groundcover/herbaceous plants in swales and herbaceous plants only in planters. The plants must be spaced to cover the area within 3 years.
 - b. Onsite Facilities (swales and planters):
 - Three large shrubs, four small shrubs/100 ft²*
 - The remainder of the area must be planted with groundcover/herbaceous plants in swales and herbaceous plants only in planters. The plants must be spaced to cover the area within 3 years.
- * Onsite facilities located in areas where sustained lines of sight are required must have ONLY small shrubs and the remaining area planted with groundcover/ herbaceous plants, as applicable. In these locations, instead of three large shrubs and four small shrubs, six small shrubs per 100 ft² are required.*
- c. Dry Pond Facilities:
 - Landscaping designs for dry pond facilities will be site specific and designed on a case-by-case basis. General requirements are described below but may be modified as necessary to meet design objectives, subject to City approval.
 - Native grass seed mix (90% coverage minimum) or 115 herbaceous plants/100 ft² extending up to the water quality design surface.

- The remainder of the area must be planted with native grass seed mix (90% coverage minimum), or groundcover/herbaceous plants (90% coverage minimum) and four shrubs per 100 ft². Appropriate size of shrubs will be site specific with special consideration given to maintenance impacts on city-maintained facilities.
- Plantings specified for city-maintained facilities must not require mowing more than once annually. Additional guidance is provided in Appendix E 10.03 Planting Matrix and Appendix E 10.05 Example Water Quality Facility Design Guide Drawings.

2. Tree Requirements:

a. Street-side Facilities:

- Trees must be incorporated as necessary to minimum street tree spacing requirements. Where tree installation is not feasible, such as in street side planters with step-out zones or lined facilities, street tree requirements must be met outside of the stormwater quality facility.
- Trees should be kept in line along a block length by holding the same distance off centerline regardless of whether the tree is placed in a standard planter strip, a street-side stormwater quality facility, or a curb extension.
- Trees may not be planted in clear vision areas or otherwise interfere with required sight distances, including intersections and railroad crossings.
- Trees are not allowed in lined facilities.

b. Onsite Facilities (Swales and Planters):

- In Moisture Zone A, one tree per 100 ft² of facility area is required, or the number of the trees per applicable Development Code requirements, whichever is of greater quantity.
- Trees are not allowed in lined facilities.
- Planters less than or equal to 3 ft wide require special consideration for tree selection. See planting matrices in Appendix E 10.03 Planting Matrix & Example Planting Diagrams for trees identified as appropriate for this application.

c. Dry Ponds:

- Tree requirements for dry pond facilities will be site specific and designed on a case-by-case basis. General requirements are described below but may be modified as necessary to meet design objectives, subject to City approval.
 - One tree per 300 ft² of area measured from the top of bank to the limits of the property. Trees must be planted such that the dripline at maturity does not extend over the top of bank, access roads, or other structures requiring maintenance. Additional guidance is provided in Appendix E 10.03 Planting Matrix and Planting Diagram Examples and Appendix E 10.05 Water Quality Facility Design Guide Drawings.

3. Size. Minimum plant size at installation:

Herbaceous Plants:	4-inch pot container
Small Shrubs/Groundcover:	1-gallon container
Large Shrubs:	30-inch height
Deciduous Trees:	1-inch caliper; 2½-inch caliper if street tree
Evergreen Trees:	7-ft height

4. Street-side facilities and onsite swales and planters must have a minimum of 50% evergreen plants, by number.
5. Street-side facilities and onsite swales and planters must have at least 2 species from the Herbaceous plant community.
6. Placement of vegetated stormwater quality facilities within a Natural Resource Overlay District is only allowed as specified in the Albany Development Code. Additional requirements for plant selection, such as the use of native vegetation, may be applicable.
7. Deep rooting trees and shrubs may not be planted in lined facilities, on top of public utilities, or within 10 ft of retaining walls, inlet/outlet structures or other culverts. See planting matrices in Appendix E 10.03 Planting Matrix and Planting Diagram Examples for suitable plants in these locations.
8. Street-side shallow swales must have a 12-inch groundcover zone from back of curb. In this zone, only low groundcover that can withstand foot traffic may be planted. All groundcover plants in the plant matrix meet this requirement.
9. O&M Warranty Period: Any contractor or developer constructing vegetated facilities which will be publicly owned or maintained is responsible for maintaining all stormwater management features per requirements set forth in the Construction Specifications 107.15.02, 210.08.00, and 605.03.00. This includes maintaining, repairing, and/or replacing plants and/or trees; any structural or functional repairs; and the mowing, pruning, mulching, and regular summer irrigation.

E 3.07 OPERATION & MAINTENANCE

- A. Ownership. Facilities constructed within the public ROW will typically be City owned and maintained. Facilities constructed within a residential subdivision to serve multiple properties (i.e., a dry pond), or other more regional style facilities located within dedicated tracts, lots, or easements will typically be public. Facilities constructed to serve single lots, and those to serve larger site developments such as commercial, industrial, or multi-family developments will typically be private. The City has sole discretion regarding public vs. private ownership.
- B. Maintenance Required. In order to function for their intended purpose over the long term, stormwater quality facilities must be periodically maintained. Following completion of the warranty period, public facilities will be maintained by the City of Albany. Private facility maintenance is the responsibility of the property owner.

Per Title 12 of the Albany Municipal Code, private stormwater quality facilities require that the owner sign a Private Stormwater Facilities O&M Agreement with the City, committing the owner, and future owners, to certain O&M activities. The standard O&M Agreement and required operations and maintenance activities are located in Appendix E 10.04 Operations & Maintenance Agreement and Checklists. The O&M practices have been adapted from the Clean Water Services – Low Impact Development Approaches Handbook. Use of non-standard facilities that have been approved by the City Engineer will require submittal of an O&M checklist specific to the authorized facility, for approval by the City.

Appendix E 10.04 Operations & Maintenance Agreement and Checklists does not provide maintenance checklists for manufactured facilities. Manufactured facilities must be maintained according to manufacturer's recommendations.

E 4.00 – STORMWATER QUANTITY MANAGEMENT DESIGN & CALCULATIONS

E 4.01 GENERAL REQUIREMENTS

Storm drainage design within a development area must include provisions to adequately control runoff from all public and private streets and the roof, footing, and area drains of residential, multifamily, commercial, or industrial buildings, and to ensure future extension of the drainage system to the entire drainage basin in conformance with the AMC and adopted Stormwater Management Plans. Control of both water quantity and quality shall be included as part of the design considerations. Provisions that must be met are:

- A. Surface or subsurface drainage, caused or affected by the changing of the natural grade of the existing ground or removal of natural ground cover or placement of impervious surfaces, shall not be allowed to flow over adjacent public or private property in a volume and/or rate or location materially different from that which existed before development occurred, but shall be collected and conveyed in an approved manner to an approved point of disposal. Requirements of the Albany Building Division shall also be met regarding alteration of drainage patterns.
- B. Surface water entering the subject property shall be received at the naturally occurring locations and surface water exiting the subject property shall be discharged at the natural locations with adequate energy dissipators within the subject property to minimize downstream damage and with no diversion at any of these points.
- C. The approved point of discharge for all stormwater may be a storm drain, existing open channel, creek, detention, or retention pond approved by the City Engineer. Acceptance of suggested systems will depend upon the prevailing site conditions, capacity of existing downstream facilities, and feasibility/maintainability of the alternate design.
- D. When private property must be crossed in order to reach an approved point of discharge, it shall be the developer's responsibility to acquire a recorded drainage easement (dedicated to the City) from the private property owner meeting the approval of the City Engineer. The developer must secure all signed easement documents from private property owners prior to final plan approval.
- E. The peak discharge from the subject property may not be increased from conditions existing prior to the proposed development except where it can be satisfactorily demonstrated by the applicant that there is no adverse impact.
- F. Retention/detention facilities must be provided in order to maintain surface water discharge rates at or below the existing design storm peak discharge except where it can be demonstrated by the applicant that no adverse impact will result from not providing said facilities. A basin analysis may be required to ensure the detention system does not adversely impact the operation of the storm drain system to which it is discharging.
- G. All storm drain system designs (conveyance, flow restrictions, detention) shall make adequate provisions for collecting all stormwater runoff. The system shall accommodate all runoff from upstream tributary areas whether or not such areas are within the proposed development. The amount of runoff to be accommodated shall be based on ultimate development of all upstream tributary areas.

Proposed storm drain systems shall not discharge flows into inadequate downstream systems unless approved by the City Engineer.
- H. All other State and Federal permitting requirements must be met. The Developer shall produce copies of approved permits for the City prior to final plan approval.

E 4.02 RUNOFF CALCULATIONS AND SYSTEM CAPACITY

Calculations for storm drain design shall be submitted with all storm drain improvement projects. Calculations shall clearly show how flows were calculated and also how the proposed storm system is capable of conveying these flows. For projects that require detention, full pre-development and post-development calculations shall be submitted.

Basin maps shall be submitted with all calculations and shall show clearly how stormwater is being routed through the improvements.

- A. Rational Method. The rational method is an acceptable way to calculate peak discharge for the sizing of storm drainage conveyance systems for laterals and collector systems in which detention is NOT required. It may NOT be used to size detention systems or trunk lines or for projects that are greater than 100 acres in size. Refer to Section E 4.02.D Drainage System Capacity to determine which design storm the improvement must convey.

$$\text{Equation} \quad Q = C \times i \times A$$

Where:

- **Q** is peak flow in cubic feet per second
 - **C** is a runoff coefficient determined by ground cover. The engineer must document the methodology used in determining the value proposed.
 - **i** is rainfall intensity in inches per hour. Rainfall intensity found on the ODOT Zone 7, I-D-F curve (see Section E 10.02-B - Appendix) shall be used. For the rational method, the basin time of concentration is used as the storm duration. The time of concentration must first be calculated (see Section E 4.02.C Time of Concentration), then the rainfall intensity can be read from the I-D-F curve.
 - **A** is the basin area in acres.
- B. Basin Hydrographs. Runoff hydrographs will be required for all volume based design. The method for development of hydrographs is the Santa Barbara Unit Hydrograph (SBUH) method. Similar unit hydrograph methods such as the Soil Conservation Service (SCS) TR-55 method or a continuous runoff model may be used if approved in advance by the City Engineer. Runoff hydrographs are dependent on a selection of variables summarized below:
- Basin Area. The total area of pervious and impervious surface areas within a drainage basin, shall be quantified in order to evaluate critical contributing areas and the resulting site runoff. Each area within a basin shall be analyzed separately and their hydrographs combined to determine the total basin hydrograph. Areas shall be selected to represent homogenous land use/development units.
 - Time of Concentration (see E 4.02.C Time of Concentration).
 - Curve Number (CN). The CN takes into account the ground cover and the soil type. County soil surveys shall be used to determine the soil type. The SCS “Urban Hydrology for Small Watersheds” handbook shall be used in determining the hydrologic classification for soils. Most soils in Albany are group “C” or “D.”
 - Rainfall distribution. Albany has a Type IA rainfall distribution.
 - Total 24-hr Rainfall (See Section E 10.01 – 24-Hour Rainfall for Albany)
- C. Time of Concentration. The time of concentration is the time for runoff to travel from the hydraulically most distant point in the watershed to the point of reference downstream. Time of concentration calculations shall be submitted for review.

There are three components that shall be considered when determining time of concentration: sheet flow, shallow concentrated flow, and channel/pipe flow. Each of these should be calculated separately and then added together to determine the basin time of concentration.

1. Sheet Flow. This is the first leg of runoff. It is generally accepted that sheet flow only occurs for a maximum of 300 ft before the flow regime turns to shallow concentrated flow. Sheet flow shall be calculated using the Manning’s kinematic solution:

$$T_t = 0.007(nL)^{0.8} / (P_2)^{0.5}S^{0.4}$$

Where: T_t = Travel Time (hours)
 n = Manning’s n
 L = Length of flow (feet)
 P_2 = 2-yr, 24-hr rainfall (inches)
 S = Slope (feet/foot)

2. Shallow-Concentrated Flow. To determine the flow time of runoff in the shallow-concentrated flow regime, you need to estimate the flow velocity. Use the figure in Section E 10.02 – Appendix in determining the flow velocity of the shallow concentrated flow. Once the velocity is estimated, divide the distance of flow by velocity to get flow time.
3. Channel/Pipe Flow. Use Manning’s equation to calculate velocities in the channels and pipes, then divide flow length by velocity to get flow time.

The three runoff flow components shall be added together to determine the total time of concentration. A map showing the assumed flow path shall be provided with the time of concentration calculations.

- D. Drainage System Capacity. For design purposes, it is necessary to define the various parts of the storm drainage system and to specify the magnitude of flow that each part must be capable of carrying.

Pipes, culverts, and ditches shall be designed to convey the peak discharge of the storm shown in the Table 4.02 below.

TABLE E 4.02-A		
Element	Definition	24-Hr Design Storm
Catch Basins/Inlets	Catch basins and inlets located within roadways.	10-yr
Feeder	Pipe/ditch of any size that serves a private development or single subdivision of 5 acres or less.	10-yr
Collector	Pipe/ditch of any size that serves multiple private developments/subdivisions or a single private development or subdivision equal to or greater than 5 acres within the same drainage sub-basin.	25-yr
Trunk	Drainage improvements that serve more than 100 acres and/or multiple drainage sub-basins as defined in the City’s Stormwater Master Plan(s) or as otherwise required by the City Engineer.	50-yr

E 4.03 SUPPORTING DATA

- A. Background computations for sizing drainage facilities shall include:

1. Peak discharge rate and volume of surface water for the design storm currently entering and leaving the subject property; or if the City Engineer determines that the property is in an interim flood hazard area, then a 50-yr storm shall be used.

Discharge volumes shall be computed for both the current land use conditions and full development of the tributary basin area.

2. Peak discharge and rate of runoff that will be generated within the subject property due to the design storm after development occurs.
3. Peak discharge and rate of runoff that will be generated by the design storm at all naturally occurring points of discharge from the property (cubic feet per second, predevelopment, and post-development). For projects that require detention, 2-yr, 5-yr, 10-yr, and 25-yr storms must be analyzed.
4. The proposed methods of handling, storing, and discharging of peak loads:
 - a. Proposed improvement for handling the computed runoff, including the location and capacity of all natural or proposed drainage facilities and easements. The method of discharging storm drainage offsite at the naturally occurring location and provisions needed to control the velocity, volume, and direction of the discharge in order to minimize damage to other properties, stream banks, and overall water quality.
 - b. Drawings of proposed open channel and closed conduit system to be shown on construction drawings.
 - i. Proposed cross-section of the channel with stable side slopes shown on the plan.
 - ii. For open channel improvements, the water surface elevation (backwater curve) of the flow for the design storm shall be indicated on the cross-section.
 - iii. For closed conduit improvements, the hydraulic grade line (HGL) of the flow for the design storms shall be indicated on the cross-section.

E 5.00 – PIPES AND CLOSED CONDUIT

E 5.01 GENERAL

All storm drains shall be laid on a consistent and uniform grade as specified in the latest edition of **Albany's Standard Construction Specifications**. Changes in piping size and grade shall only occur at manholes. All pipes and closed conduit materials shall conform to the *Standard Construction Specifications*. Joints shall have gaskets and be water tight.

E 5.02 PIPE SIZE

The minimum size for storm drains shall not be less than ten inches inside diameter and shall begin at a structure and shall terminate at an approved point of disposal. Proposed exceptions to the above will be reviewed and considered for approval on a case-by-case basis by the City Engineer of Public Works. When two parallel pipes are installed in-lieu-of one large pipe or a box culvert, the minimum separation between the pipes shall be one (1) foot or one-third the diameter of the largest diameter pipe, whichever is greater. This requirement may be waived if the void between the pipes below the spring line is filled by grouting or other approved method/substance.

E 5.03 GRADE

All storm drains shall be laid on a grade that will produce a mean velocity (when flowing full) of at least 3 feet per second (fps), based upon Manning's pipe friction formula using a roughness coefficient valued at not less than 0.01, or the pipe manufacturer's recommendations, whichever is greater.

The minimum grade may be reduced to produce an absolute minimum velocity of 2.0 fps upon approval of the City Engineer. But the grade of any pipe, regardless of diameter, shall not be less than .002 feet per foot (feet/foot) unless otherwise authorized by the City Engineer. Other cases requiring a flatter grade than permitted above shall also be reviewed on a case-by-case basis for approval by the City Engineer.

Engineers are cautioned not to specify storm drains of sizes that are obviously larger than is necessary for satisfactory carrying capacity, but which are specified solely in order to meet grade requirements, i.e., a 12-inch pipe for a 10-inch pipe to acquire a decrease in slope.

The maximum grade for storm drains will generally be limited such that pipeline velocities when flowing full do not exceed 15 fps. If, out of necessity, velocities greater than this will result, ductile iron piping shall be used. Outside drop manholes with flatter pipe slopes can also be used.

E 5.04 ALIGNMENT

Generally, storm drains shall be laid on a straight alignment between catch basins and between manholes:

- A. Where storm drains are being designed for installation parallel to other utility pipe or conduit lines, the vertical location shall be in such a manner that will permit future side connections of main or lateral storm drains and avoid conflicts with parallel utilities without abrupt changes in vertical grade of main or lateral storm drains. Location within easements or rights-of-way shall be in accordance with the *Standard Construction Specifications*. A minimum separation of 10 ft shall be maintained between storm drain lines and all other public utilities.
- B. Under normal conditions, storm drains shall be located in the street ROW 10 ft from the centerline and preferably on the low side and on the south and west sides of the street, except when curb inlet locations warrant otherwise. Piping between curb inlets and storm drain lines shall be at near right angles to the street and other utility lines. All exceptions shall be reviewed on a case-by-case basis for approval.
- C. Easement locations for public storm drains serving a public utility district (PUD), apartment complex, or commercial/industrial development shall be in parking lots, private drives, or similar open areas that will permit an unobstructed vehicle access for maintenance by City forces.
- D. Easements must be furnished to the City for review and approval prior to recording. The City will record the easements after City Council acceptance. Each easement shall be according to the City's standards.

E 5.05 COVER REQUIREMENTS

Storm drains shall be at a minimum depth of 3 ft or greater below the finish grade elevation. Minimum pipe depth shall be measured between the finished surface grade at the centerline of the storm drain and the top of storm drain pipe. Storm drains at depths less than this create problems with water line crossings, sewer lateral crossings, and proper cover over the pipe per manufacture's recommendations. Fill may be required on development sites to maintain adequate cover over sewer lines.

In some extreme locations where flat terrain limits the extension of storm drains, the City Engineer may allow some pipeline configuration changes as well as alternate pipe cover depths in conjunction with site filling. Storm drain pipes with depths less than 3 ft, where allowed by the City Engineer, shall be connected from catch basin to catch basin in lieu of the use of manholes. Special pipe material such as ductile iron pipe (down to 30 inches of cover) or reinforced concrete pipe (down to 18 inches of cover) will be required.

In areas of flat terrain, the design engineer must show that sufficient depth is provided at the boundary of the development to properly drain the remainder of the upstream basin area tributary to the site or that other drainage options are available to the upstream property.

E 6.00 – INLETS, OUTLETS, CONNECTIONS

E 6.01 CURB INLETS

- A. Curb inlet basins may be connected together (maximum of four) at intersections to minimize the number of pipe crossings of the streets and number of manhole penetrations required. Curb inlet piping shall be connected to the storm drain system at manholes.
- B. Inlets shall be spaced to assure that the flow in the streets can be intercepted and no ponding in the street occurs during the design storm. However, the maximum total length of curb and gutter that may be drained by a curb inlet is 400 ft. Curb inlets shall be located on the upstream side of curb returns. In addition, catch basins shall be installed where street improvements end on a descending grade and shall be piped to an approved point of disposal.
- C. The width of gutter flow on local streets shall not exceed 8 ft from face of curb or top the curb for a 10-yr design storm at any point along the street. Width of flow on other street classifications shall not extend into the travel lanes or overtop the curbs for a 25-yr design storm at any point along the street.
- D. Curb inlets on local streets shall be designed to completely intercept the 10-yr design storm gutter flow. Curb inlets on all other street classifications shall be designed to completely intercept the 25-yr design storm gutter flow.
- E. Curb inlets shall be located so as not to interfere with other construction elements (e.g., driveways, pedestrian ramps, etc.). Exceptions will be considered on a case-by-case basis.

E 6.02 SURFACE DRAINAGE INTERCEPTION

Inlet structures shall be built wherever a surface drainage (creek/ditch/swale) is intercepted and placed into a piped system. The inlet structure shall be concrete. All inlet structures for pipes shall have grating covering the inlet. The grate shall have the bars oriented in the vertical direction. The inlet grate shall be removable.

The invert of the inlet structure shall be at or below the invert of the drainage being intercepted. The inlet shall be designed to accommodate the anticipated peak flows of the surface drainage at the design storm outlined in Table E 4.02-A.

Special attention shall be paid to where water will accumulate and flow should the inlet become clogged or blocked. In sensitive areas, accommodations for overflows caused by inlet clogging shall be made such that the overflow does not damage downstream areas.

E 6.03 SLOPE INTERCEPT INLETS

Slope intercept drains shall be provided at the following locations:

- A. Along the upper boundaries of a development where the natural ground slope exceeds 10% to intercept drainage from the tributary area above the site.
- B. Along the lower boundary of a development where the natural ground slope exceeds 10% to prevent drainage onto a lower tributary area other than by means of an approved point of disposal.
- C. Along the top of all cuts that exceed 4 ft with cut slopes that exceed 2:1 where the tributary drainage area above the cut slopes towards the cut and has a drainage path greater than 40 ft, measured horizontally.

E 6.04 SUBSURFACE DRAINAGE INTERCEPTION

Subsurface drains (underdrains) shall be provided at the following locations:

- A. On all cut and fill slopes in excess of 4 ft for stability except when a soils report submitted by a registered professional engineer experienced in soils certifies they are not required.

- B. For all existing springs or springs intercepted during construction activity for other facilities, i.e., sewer, water mains, or street excavations.
- C. Where high ground water exists or when it is necessary to reduce the piezometric surface to an acceptable level to prevent land slippage or underfloor flooding of buildings.

The drainage line installed shall begin at a cleanout and terminate at an approved point of discharge. Open-jointed storm drain lines will not be considered as an acceptable solution.

E 6.05 OUTLETS INTO SURFACE DRAINAGE CHANNELS

Storm drain lines shall enter a creek or drainage channel at 90° or less to the direction of flow. The outlet shall have a head wall and scour pad or riprap to prevent erosion of the existing bank or channel bottom. All outlet structures for pipes of 24 inches in diameter or greater shall have grating covering the outlet. The grate shall have the bars oriented in the vertical direction. Outlet grates shall be attached to the outlet structure with a hinged connection at the top of the grate.

The outlet shall not intrude into the channel and reduce flow capacity of the channel. Pipe ends shall be beveled to match the side slope of the channel. Energy dissipation measures and armament of the opposite channel bank are required at the outlet. The size of the receiving facility will govern what protective measures are required

Backflow valves may be required on outlet structures to prevent backwater from surcharging and flooding the new storm drain improvements.

Permits from outside agencies such as the Oregon Department of State Lands (DSL), the US Army Corps of Engineers (Corps), and the Oregon Department of Environmental Quality (DEQ) may also be required.

E 6.06 MANHOLES

Changes in piping size and grade shall only occur at manholes. In general, storm drains shall be designed to have access for cleaning no further than 450 ft apart. Manhole rims in unimproved areas shall be a minimum of 12 inches above the surrounding ground and be marked with a metal marker post.

- A. All connections, junctions, changes of grade, changes in size and alignment shall be made at manholes. Tee connections in storm lines shall not be allowed (with the exception of four- and six-inch service laterals). All private connections to the public system shall be reviewed on a case-by-case basis. Private connections to the public system might be allowed using a tee connection under specific conditions.
- B. Where the pipe size decreases upstream through the manhole, the upstream pipe crown shall match the elevation of the crown of the downstream pipe. Where grade is limited, matching 0.8 of the pipe diameters may be used.
- C. In some extreme locations where flat terrain limits the extension of storm drains, the City Engineer may allow some pipeline configuration changes in conjunction with site filling. Storm drain pipes with depths less than 3 ft, where allowed by the City Engineer, shall be connected from catch basin to catch basin in lieu of the use of manholes.

E 7.00 – SURFACE DRAINAGE

E 7.01 SURFACE DRAINAGE

For purposes of these Engineering Standards, surface drainage routes will be classified according to two general categories: constructed watercourses and natural creeks.

- A. Plan requirements for surface drainage courses shall include the requirements previously specified in Section E 2.00 Stormwater Plan and the following supporting data and calculations:
 - 1. Profile of the channel showing the existing flowline and top of bank, proposed flowline and top of bank, and design water surface profile (backwater curve).
 - 2. A minimum of three cross sections of the existing channel adjoining or crossing the property taken at the upstream, midsection, and downstream boundaries of the property. More sections may be required depending on the length of the reach and existing channel alignment.
 - 3. Calculations for arriving at the design flow rate: the City will furnish the flow rate when records are available. Analyze the proposed system and show that the channel cross section after improvement will pass the design storm with one foot of freeboard to the top of bank. For channels shown on the F.I.R.M. maps, show that the channel cross section after improvement will pass the base flood at or below the 100-yr flood elevation shown on the F.I.R.M.
 - 4. Open channels shall have easements sufficient in width to cover the 100-yr Floodplain Line when a 100-yr design storm is required or 15 ft from the top of the recognized bank, whichever is greater.

E 7.02 CONSTRUCTED WATERCOURSE REQUIREMENTS

- A. Constructed watercourses shall be designed with a "natural" curved alignment with a variable side slope not to exceed four to one (4:1), except that in tight spots created by existing natural features (e.g., boulders, large trees, etc.) where the slope can be three to one (3:1) until the natural feature is bypassed or where steeper slopes are needed and do not impair the hydraulic efficiency of the waterway. The watercourse shall include a low flow channel as described below and will be reviewed on a case-by-case basis for approval.

The bank shall be designed with 1 ft of freeboard above the design storm with a minimum top of bank width of 6 ft. A larger width shall be provided when required by the City Engineer for maintenance purposes. The backslope of the bank shall not exceed two horizontal to one vertical (2:1). The existing ground adjacent to the toe of the bank backslope shall be graded to slope away at 2% to prevent water ponding at the backslope toe.

- B. Design shall be curvilinear with a 100-ft minimum radius. Tighter curves may be used if the City Engineer determines that sufficient erosion control has been incorporated into the design to maintain stable bank conditions following development.
- C. A low flow channel shall be designed to carry a 2-yr design storm or the normal low water flow of a year-round creek, whichever is greater. Low flow channel slopes shall not exceed two to one (2:1) and shall be stabilized to the satisfaction of the City Engineer. In general, bank stabilization will be required in any channel with a design flow velocity in excess of 3 fps.
- D. Capacity of channels shall be determined by the Manning Formula. The value for “n” shall be 0.033 for maintained grass-lined swales. The value for “n” shall be 0.035 for channels with rock-lined bottoms.
- E. Existing ditches approved for the point of discharge for storm drains and culverts shall be provided with rock-lined bottoms and side slopes at the discharge point of storm drain or culvert. The rock shall extend for a minimum distance of 8 ft downstream from the end of the storm drain or culvert.

- F. All channel sides and bottoms shall be seeded, sodded, or rock lined immediately following construction. Bank stabilization measures shall be designed and included in the construction plans.
- G. Points of discharge from culverts and storm drains into ditches and swales 15% or greater in grade shall be rock lined with boulders with one face a minimum of 24 inches in dimension. Said rock lining shall extend for a distance of 10 ft minimum from the point of culvert or storm drain discharge and shall have a width 3 ft in excess of the diameter of the culvert or storm drain. Special energy dissipators may be substituted for boulders at the discretion of the City Engineer.

E 7.03 NATURAL CREEK REQUIREMENTS

A permit must be obtained from the Division of State Lands and the Department of Fish and Wildlife for all work between the creek banks.

- A. Natural creeks shall be preserved and all work in and adjacent to creeks shall incorporate both temporary and permanent erosion control measures to protect disturbed areas from erosion and damage. No alteration will be permitted that reduces the overall creek capacity.
- B. Creek channel design and construction practices shall be such that the cumulative incremental effects of creek work considered alone or together with existing or similar projects in the vicinity will not result in substantial damage to existing waterways and surface waters by erosion, siltation or sedimentation, significant changes in water quality, increased downstream water velocity, significant harmful deterioration of groundwater drainage, or significant deterioration of aquatic wildlife habitat as determined by the City Engineer.
- C. Creek construction, relocation, and/or reconstruction may be approved if the City Engineer determines that such a proposal will result in an overall benefit to or maintenance of a surface water system of equal quality in terms of water quantity and quality control and the Developer can obtain the appropriate State and Federal permits.
- D. Any and all stream work shall be consistent with the floodplain management policies and regulations and as set forth in AMC or any amendments thereto.
- E. Any and all stream work shall be consistent with the *Stormwater Management Plan*.

E 8.00 – STORMWATER DETENTION

E 8.01 GENERAL REQUIREMENTS

- A. All storm drainage runoff originating from and/or draining to any proposed development shall be controlled and/or conveyed in accordance with all City standards and policies as described in these Engineering Standards. When existing conditions make storm drainage detention impossible for a portion of a site, the City Engineer may permit compensatory storage volume to be provided on another portion of the site, provided the total site area is tributary to one drainage basin both prior to and after development. In no case shall the runoff rate from the total site exceed the allowable release rate.
- B. Detention facilities shall be open basins, ponds, underground storage (pipe/chamber), or combinations thereof. Ony dry ponds may be designed as combined facilities to address both detention and water quality requirements. DEQ does not allow detention ponds as stand-alone treatment facilities if settling is the only mechanism to address water quality. Dry ponds are allowed for meeting water quality requirements as runoff is filtered through soil media before discharging from the facility. Other than dry ponds, all detention and water quality facilities must be separate, and designed to operate in series.
- C. Detention requirements may be waived by the City Engineer on a case-by-case basis.
- D. Detention basins will be required to detain post-developed runoff from the 2-yr, 5-yr, 10-yr, and 25-yr, 24-hr storm to pre-developed quantities. If the project area is greater than 100 acres or covers multiple drainage sub-basins, then the 50-yr, 24-hr storm must also be detained to pre-developed peak volumes.

Potential downstream damage due to detention system failure/overflow may require greater detention requirements or improvements downstream. In no case shall the release rates increase the flooding conditions downstream. An emergency overflow must be designed to accommodate 100-yr storm flows.

- E. A flow control structure must be used to restrict flow rates exiting a detention facility. For ponds, refer to the Water Quality Facility Design Guide Drawing in Appendix E 10.05 for an example of an acceptable control structure design.
- F. The minimum allowable diameter for an orifice in a flow control structure shall be two inches due to the possibility of clogging or plugging.
- G. All detention ponds shall have emergency overflow structure incorporated into their design. Flow capacity of the overflow shall be calculated and shown in supporting information. The emergency overflow shall accommodate the potential peak flow conveyed to the facility up to a 100-yr storm event.
- H. Stormwater plans shall include a plan and profile of the facilities. The profile requirement for private drainage systems may be waived at the discretion of the City Engineer when sufficient data is provided on the plan in a clear and concise manner including the following minimum hydraulic and physical data: 1) grades, bottom elevations of ditches, channels, ponds and swales, parking lots and recharge trenches; 2) inverts of pipes; 3) inverts and tops of all structures such as manholes, catch basins, chambers, or similar structures; and 4) size, length, and slope of all pipes or other detention or conveyance facilities, including the invert elevations of the existing or any other storm drainage system the subject drainage proposes to discharge into. The design volume of all detention ponds shall also be shown on the plan as well as a note indicating that ponds shall be inspected prior to landscaping.
- I. All aspects of the onsite drainage system must be properly designed to handle all flows developed onsite and all flows that flow through the site from upstream. Designers should conceptualize how water will move into, through, and out of the system, looking for such potential problems as flow impediments, construction difficulties, future maintenance problems, and soil erosion potential.
- J. All aspects of public health, safety, maintenance, nuisance abatement, and vector control must be carefully reviewed in every drainage control system plan. Protective measures are often necessary and shall be required whenever appropriate. The protective measures themselves shall be designed so as not to constitute hazards or nuisances.
- K. The impact of a system failure should be analyzed both in terms of onsite and off-site effects. The impacts may be to adjacent properties, or to elements of the public drainage system or other private systems. The downstream consequences of failure of a detention pond shall be included in determining location and design parameters.
- L. The frequency and difficulty of future maintenance can be minimized by thorough consideration during design of what could possibly go wrong in the system and what would be required to correct the problem. Facility design must incorporate maintenance considerations to ease such problems.
- M. The use of the site should be evaluated to determine if hazardous materials or other pollutants are likely to be present, and if extraordinary design considerations are necessary.
- N. It is important that runoff from rooftops pass through the detention system; the design should clearly indicate how roof runoff moves through the system.
- O. All weather access, passable by a maintenance vehicle, to all control structures shall be provided. Easements dedicated to the City may be required.

E 8.02 SURFACE PONDS

- A. Slopes on all interiors of surface ponds shall not exceed 3 ft horizontal to one foot vertical. If interior side slopes of surface ponds need to be mowed then the interior side slopes shall not exceed 4 ft horizontal to one foot vertical. Slopes on pond exteriors shall not exceed two horizontal to one vertical.

- B. The maximum depth of any pond shall be 4 ft.
- C. Ponds suited to multiple use are encouraged. Examples of multiple uses are sport courts, play areas, neighborhood parks, and picnic areas. Such ponds that will provide public access shall be designed with special attention to safety of the public during inundation of the pond. Side-slopes shall be very gradual to avoid the risk of someone slipping into the pond and not being able to walk out.
- D. All ponds shall be landscaped so as to provide slope stability and pleasant appearance by utilizing sodding, seeding, and planting of trees and shrubbery. Under no circumstances shall use of easily floatable or erodible materials (such as “bark dust”) be permitted in pond interiors.
- E. Maintenance of surface ponds in commercial, industrial, and multifamily developments shall be the responsibility of the property owner or owner’s association. Maintenance of detention pond landscaping in single-family residential areas and PUD developments shall be the responsibility of an owner’s association or community club and shall be so stated on the face of the plat unless accepted for maintenance by the City. Failure to maintain a weed abatement program will be cause for the City to perform the work and bill the owner or owners. Combined detention and water quality ponds in single-family residential development will be maintained by the City.
- F. Where berms or embankments are to be constructed as banks of detention or water quality ponds, they shall be designed and constructed in compliance with the Oregon Structural Specialty Code by a certified and experienced independent geotechnical engineer. The geotechnical engineer shall stamp the plans for berm construction and certify that the berms are safe for the intended use. Notes to the effect of the above shall be shown on the plans submitted for approval.
- G. All City-maintained detention pond control structures not abutting a public ROW shall be accessible to the City of Albany for maintenance and operation. Access easements shall be provided, which shall be a minimum 12 ft wide and shall be improved to accommodate vehicular traffic year-round. Control structures shall be designed to operate automatically as much as possible.
- H. A vehicular access must be provided to the bottom of the detention pond when the bottom width of the pond is 20 ft or greater and/or when the height of the pond interior wall exceeds 5 ft.
- I. The access grade into the proposed retention/detention pond shall be no steeper than 5 ft horizontal to 1 ft vertical.
- J. Minimum freeboard shall be one foot above the highest potential water surface elevation (one foot above the emergency overflow structure or spillway elevation).
- K. The minimum distance from the edge of the maximum water surface elevation to property line is 20 ft. Minimum distance from the toe of the pond berm or embankment to the nearest property line is one-half of the berm height and a minimum of 5 ft. Minimum distance from the edge of the maximum water surface elevation to the top of a slope greater than 12% is 200 ft, unless a geotechnical report is submitted and approved by the City. Minimum distance from the edge of the pond water surface to a well is 100 ft.
- L. All berms and embankments shall have a minimum top width of 5 ft. Where maintenance access is provided along the top of a berm, the minimum top width of the berm shall be 15 ft. The bottom of all constructed and graded retention/detention ponds shall be sloped no flatter than 0.01 foot/foot (1%) toward the outlets for drainage.

EXCEPTION: This requirement need not apply to natural ponds, which exist and are utilized for stormwater detention.
- M. All detention ponds shall have a well-defined low flow channel to contain runoff of lesser storms. Any low flow channel shall be designed so as to enhance the pond landscaping and overall pond appearance.
- N. Outlets of all detention ponds shall be provided with suitable debris barriers designed to protect the outlet from blockage or plugging. Properly-sized overflow structures shall be designed into the pond.

- O. The design volume of the detention pond shall be shown on the plan and the pond volume inspected prior to landscaping (a note to this effect shall be shown on the plans).

E 8.03 CLOSED DETENTION SYSTEM

- A. A minimum grade of 0.003 ft per foot shall be used in any pipes or vaults used for closed detention systems.
- B. The outfall control structure shall meet the standards set forth in the *Standard Construction Specifications* or as approved by the City Engineer.
- C. Access to closed detention systems shall be provided at the upstream and downstream terminus of the system. The maximum distance between access points shall be 400 ft. Improvements shall be made to facilitate maintenance equipment access to the maintenance access points year-round. Maintenance access point shall not be in areas that can be fenced off by private property owners.

E 8.04 DETENTION POND EASEMENTS

- A. All detention ponds in platted subdivisions may be required to be located in separate tracts dedicated to the City with access easements for maintenance where required.
- B. Where a detention pond is located within the boundaries of a commercial lot and not in a separate dedicated tract, the peak design discharge water surface plain shall be shown as an easement on the final plat hard copy. Restrictions shall be added to the final plat hard copy and appear on the face of the plat.
- C. A written restriction shall be added to the final plat hard copy to the affect that approval shall be obtained from the Department of Public Works before any structures, fill, or obstructions (including fences) are located within any drainage easement or delineated 100-yr flood plain area.
- D. A drainage easement shall be required for all public, closed storm drainage detention systems. The City Engineer may require wider easements where pipe diameter or vault widths exceed 4 ft.
- E. All publicly maintained storm drainage systems including collection, conveyance, and flow restrictors not located in ROW shall be located in drainage easement or tract dedicated to the City of Albany.
- F. Permanent access and drainage easements shall be granted to the City of Albany for any storm drainage detention facility, which is located in a development, and for an access road to that facility where said facility and access road are located on property other than the development but serve the development. Access roads shall provide all-weather access. The owner in fee simple and contract purchaser of the property upon which the access road and facility are to be located shall execute the said easement. The minimum access easement width shall be 15 ft.

E 9.00 – EROSION PREVENTION AND SEDIMENT CONTROL

E 9.01 EROSION PREVENTION AND SEDIMENT CONTROL

Local EPSC requirements are in addition to any state or federal permitting requirements. Title 12 of the Albany Municipal Code defines the City of Albany's Erosion Prevention and Sediment Control program. Erosion prevention and sediment control measures shown on the plans shall comply with the requirements of this program. Albany's Erosion Prevention and Sediment Control Manual can be found on the City's website on the Public Works, Engineering web page.

E 10.00 – APPENDICES

E 10.01 24-HOUR RAINFALL FOR ALBANY

The following list of 24-hour rainfall totals for the given return intervals were determined from the Regional Precipitation for Oregon data, issued January 2008, as provided by George Taylor of Applied Climate Service. The water quality storm was determined from rainfall data obtained between 1948 and 2021 at two nearby rain gauges (the CRVO Agrimet and the NOAA JEFF gauges). The rainfall analysis was used to identify a water quality storm which is estimated to represent 80% of average annual runoff.

TABLE E 10.01-A	
Return Interval	Peak 24-Hour Rainfall
Water Quality Storm	1.00 inch
2 year	2.47 inches
5 year	2.86 inches
10 year	3.37 inches
25 year	3.94 inches
50 year	4.38 inches
100 year	4.83 inches

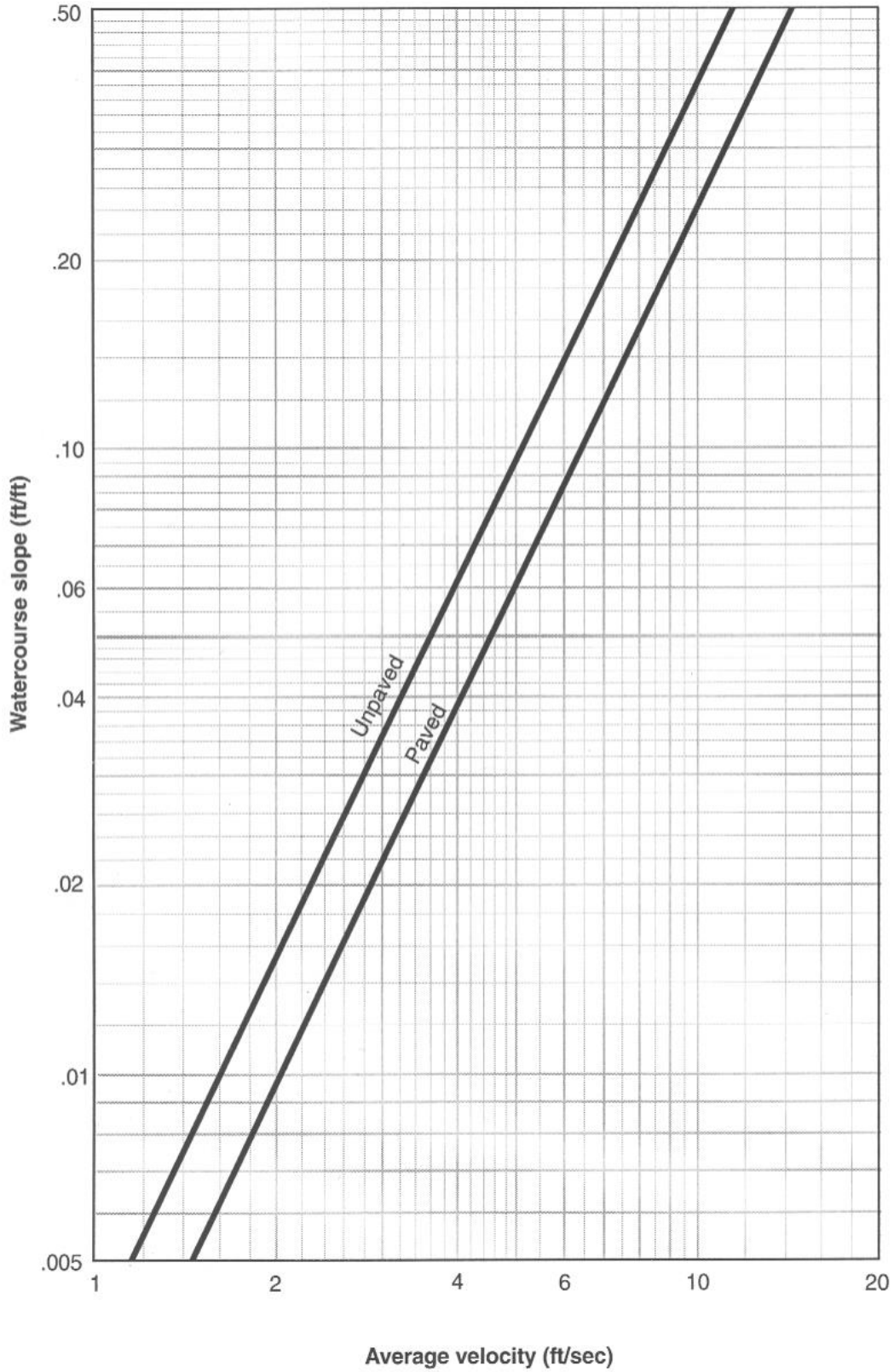

Average velocities for estimating travel time for shallow concentrated flow.

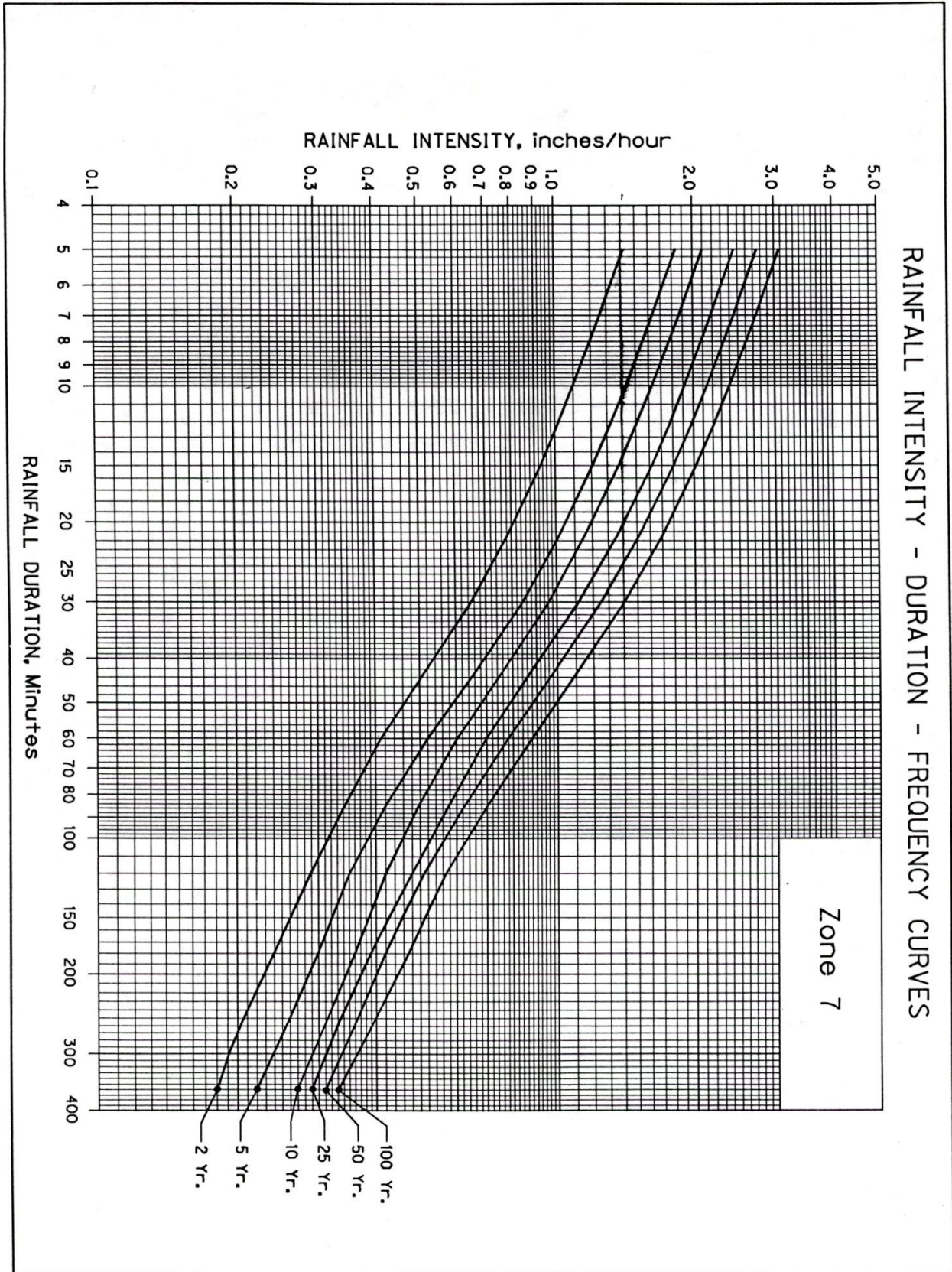

This appendix provides planting matrices with important information on plants approved for installation in Albany's stormwater quality facilities. All plants included in these matrices are drought tolerant and do not require irrigation after their establishment period. The matrices are intended to guide plant selection for each facility's planting plan. A description of the type of information provided for each plant is provided below.

- **Plant Name:** Plants are listed by their botanical name first, in italics, followed by a generally accepted common name. Note that common names vary, so use of the botanical name is recommended to ensure proper plant selection.
- **Zone:** Denotes the planting moisture zone as noted in the facility Figure 1 in which it is appropriate to locate each respective plant. Some plants work in multiple moisture zones, and others only in a particular dry, moist, or wet condition.
- **Origin:** Plants approved for stormwater facilities can be grouped into three categories: NW Natives, NW Native Cultivars, and Non-Native Adaptive plants.
 - *NW Native:* These are plants that are indigenous to our specific region. They typically require minimal care once they are planted because they have evolved and adapted to the growing conditions and climate of the region. Because of their place in the local ecology, native plants also provide habitat value for birds and other local species. For these reasons, native plants are strongly recommended for stormwater facilities and should be used whenever suitable.
 - *NW Native Cultivar:* These species are cultivated varieties of native plants produced by horticultural techniques and are not normally found in wild populations. Cultivars are bred for certain desired characteristics that make them different from their native counterparts. Native cultivars may be selected over a native plant if it is more suitable for certain conditions, such as densely urbanized applications. For example, Kelsey Dogwood (*Cornus sericea* 'Kelseyi') is a cultivar of the native Red Twig Dogwood (*Cornus sericea*). Kelsey Dogwood has been selectively bred to be much smaller at maturity than red twig dogwood, which can be advantageous in small scaled urban stormwater planters. In such instances, the native cultivar is preferred because it will not outgrow the facility or require frequent pruning maintenance, while still offering the same vegetative advantages as its native counterpart.
 - *Non-Native Adaptive:* These plants are not native to our region, but have certain characteristics that make them very useful and well adapted to stormwater facilities. The non-native adapted plants included on the stormwater facility plant lists are plants that have proven to be non-invasive.
- **Type/Size:** A range of factors to aid in plant selection showing individual plant characteristics:
 - (E)vergreen/(D)eciduous: Identifies the characteristic of a plant to keep foliage during winter months. Planting placement and selection should maintain a balance of evergreen and deciduous materials.
 - Potential Height: Identifies maximum size at maturity to use as a design guideline.
 - Typical On-Center Spacing: Identifies the optimum spacing for new plantings. This is to be used as a guideline and may vary slightly depending on site conditions.

- **Context Factors**

- *Sun/Shade*: When developing planting plans, it is important to consider if plants are going to be in full sun or shade. This column identifies which plants are appropriate for full sun or shade.
- *Facility width*: Narrow conditions require plants that are not too large and will outgrow, or have potential for roots to damage, narrow planters. This column identifies which plants are appropriate for various planter widths.
- *Lined Facility/On Top of Utilities*: In lined facilities it is important to limit larger material or plants with aggressive and deep roots. This column identifies which plants are appropriate for this application.
- *Parking Areas*: This column identifies plants that are appropriate for facilities in most parking areas. Large shrubs selected for parking areas should have form and habit that are open and transparent. Note: For portions of parking areas that have line of sight requirements, plants should be selected from the “Streets/Line of Sight” column.
- *Streets/Line of Sight*: For street-side facilities and in certain parking areas where line-of-sight visibility is required, use plant materials that do not limit necessary lines of sight visibility. This column identifies which plants are appropriate for this application. NOTE: See City of Albany’s Recommended Street Trees List for trees approved for use in Streetside Post-Construction Stormwater Facilities.
- *Adjacent to Buildings*: When planting adjacent to buildings, limit plant sizes for compatibility with building footings, windows or other systems. This column identifies which plants are appropriate to use adjacent to buildings.

Tables 1 through 3 below include stormwater facility plant lists for planters, and dry ponds respectively.

Table 1: Stormwater Facility Plant Lists: Planters

Plant Name	Zone	Origin			Type/Size			Context Factors					
		Moisture Zone (A) Uniformly Wet to Moist	NW Native	NW Native Cultivar	Non-Native Adapted	(E)vergreen / (D)eciduous	Potential Height	Typical On-Center Spacing	(S)un / (Sh)ade	Facility Width (Minimum)	Lined Facility/ On Top of Utilities	Parking Areas	Streets/ Line of Sight
Botanical Name, Common Name													
Herbaceous Plants													
<i>Carex densa</i> , Dense sedge	•	•			E	24"	12"	S	N/A	•	•	•	•
<i>Carex morrowii</i> 'Variegata', Variegated Japanese sedge	•			•	E	18"	12"	S	N/A	•	•	•	•
<i>Carex obnupta</i> , Slough sedge	•	•			E	24"	12"	S	N/A	•	•	•	•
<i>Carex rosii</i> , Ross's Sedge	•	•			D	12"	12"	S	N/A	•	•	•	•
<i>Carex rupestris</i> , Curly sedge	•			•	D	14"	12"	S	N/A	•	•	•	•
<i>Carex tumulicola</i> , Foothill Sedge	•	•			E	24"	12"	S	N/A	•	•	•	•
<i>Deschampsia elongata</i> , Slender hair grass	•	•			E	36"	12"	S	N/A	•	•	•	•
<i>Juncus ensifolius</i> , Dagger-leaf rush	•	•			D	10"	12"	S	N/A	•	•	•	•
<i>Juncus patens</i> , Spreading Rush	•	•			E	18"	12"	S/Sh	N/A	•	•	•	•
<i>Juncus patens</i> 'Elk Blue', Elk Blue gray rush	•		•		E	18"	12"	S/Sh	N/A	•	•	•	•
Small Shrubs													
<i>Arctostaphylos uva-ursi</i> , Kinnikinnick	•	•			E	18"	24"	S/Sh	N/A	•	•	•	•
<i>Cornus sericea</i> 'Kelsey', Kelsey dogwood	•		•		D	24"	24"	S	N/A	•	•	•	•
<i>Gaultheria shallon</i> , Salal	•	•			E	7'	3'	S/Sh	N/A	•	•	•	•
<i>Mahonia Nervosa</i> , Dull Oregon Grape	•	•			E	24"	24"	S/Sh	N/A	•	•	•	•
<i>Mahonia repens</i> , Creeping Oregon Grape	•	•			E	18"	18"	S/Sh	N/A	•	•	•	•
<i>Polystichum munitum</i> , Sword fern	•	•			E	24"	24"	Sh	N/A	•	•	•	•
<i>Spiraea densiflora</i> , Subplaine Spiraea	•	•			D	24"	24"	S/Sh	N/A	•	•	•	•
<i>Spiraea japonica</i> 'Goldmound', Goldmound spiraea	•			•	D	24"	18"	S/Sh	N/A	•	•	•	•
Large Shrubs													
<i>Holodiscus discolor</i> , Oceanspray	•	•			D	7'	4'	S/Sh	4'	•	•		•
<i>Lonicera involucrata</i> , Black Twinberry	•	•			D	10'	6'	S	4'				
<i>Mahonia aquifolium</i> , Tall Oregon Grape	•	•			E	10'	4'	S	4'	•			•
<i>Philadelphus lewisii</i> , Mock Orange	•	•			D	10'	4'	S/Sh	4'	•	•		•
<i>Ribes sanguinum</i> , Red Flowering Currant	•	•			D	10'	4'	S	4'	•	•		•
<i>Symphoricarpos albus</i> , Snowberry	•	•			D	6'	4'	S/Sh	3'	•	•	•	•
<i>Vaccinium ovatum</i> , Evergreen Huckleberry	•	•			E	8'	4'	S/Sh	4'	•	•		•
<i>Viburnum ellipticum</i> , Oval-leaved Viburnum	•	•			D	12'	4'	S/Sh	4'	•	•		•
Onsite Trees (No Trees in Lined Facilities)**													
<i>Acer circinatum</i> , Vine maple	•	•			D	15'	12'	S/Sh	3'		•		•
<i>Acer rubrum</i> , Red maple	•			•	D	40'	25'	N/A	6'		•		
<i>Alnus rubra</i> , Red alder	•	•			D	60'	15'	N/A	6'				
<i>Amalanchier alnifolia</i> , Pacific Serviceberry	•				D	15'	12'	S/Sh	15'		•		•
<i>Carpinus caroliniana</i> , American Hornbeam	•			•	D	25'	20'	N/A	6'		•		
<i>Crataegus douglasii</i> , Black hawthorn	•	•			D	40'	10'	N/A	6'		•		
<i>Fraxinus latifolia</i> , Oregon ash	•	•			D	30'	20'	N/A	6'		•		
<i>Malus fusca</i> , Pacific crabapple	•	•			D	30'	10'	N/A	6'	•			•
<i>Nyssa sylvatica</i> , Black tupelo	•			•	D	25'	20'	N/A	6'		•		
<i>Oemleria cerasiformis</i> , Osoberry	•	•			D	15'	10'	S/Sh	15'	•	•		•
<i>Rhamnus purshiana</i> , Cascara	•	•	-	-	D	30'	12'	S/Sh	30'	-	•	-	•
<i>Sorbus sitchensis</i> , Sitka Mountain Ash	•	•			D	20'	12'	S/Sh	20'		•		•

** See City of Albany's recommended street tree list for trees approved for use in streetside post-construction stormwater quality facilities.

Table 2: Stormwater Facility Plant Lists: Swales

Plant Name	Zone		Origin			Type/Size			Context Factors				
	Moisture Zone (A) Uniformly Wet to Moist	Moisture Zone (B) Drier Transitional Area	NW Native	NW Native Cultivar	Non-Native Adapted	(E) Evergreen / (D) Deciduous	Potential Height	Typical On-Center Spacing	(S) Jun / (Sh) Shade	Lined Facility On Top of Utilities	Parking Areas	Streets/ Line of Sight	Adjacent to Buildings
Botanical Name, Common Name													
Herbaceous Plants													
<i>Carex densa</i> , Dense sedge	•		•			E	24"	12"	S	•	•	•	•
<i>Carex morrowii</i> 'Variegata', Variegated Japanese sedge	•				•	E	18"	12"	S	•	•	•	•
<i>Carex obnupta</i> , Slough sedge	•		•			E	24"	12"	S	•	•	•	•
<i>Carex rosii</i> , Ross's Sedge	•	•	•			D	12"	12"	S	•	•	•	•
<i>Carex tumulicola</i> , Foothill Sedge	•	•	•			E	24"	12"	S	•	•	•	•
<i>Deschampsia elongata</i> , Slender hair grass	•	•	•			E	36"	12"	S	•	•	•	•
<i>Elymus glaucus</i> , Blue wild rye		•	•			E	36"	12"	S	•	•	•	•
<i>Juncus ensifolius</i> , Dagger-leaf rush	•		•			D	10"	12"	S	•	•	•	•
<i>Juncus patens</i> , Spreading Rush	•	•	•			E	18"	12"	S/Sh	•	•	•	•
<i>Juncus patens</i> 'Elk Blue', Elk Blue gray Rush	•	•		•		E	18"	12"	S/Sh	•	•	•	•
Groundcover													
<i>Arctostaphylos uva-ursi</i> , Kinnickinnick	•	•	•			E	6"	12"	S	•	•	•	•
<i>Fragaria chiloensis</i> , Coastal Strawberry		•	•			E	6"	12"	S	•	•	•	•
<i>Mahonia repens</i> , Creeping Oregon Grape	•	•	•			E	18"	18"	S/Sh	•	•	•	•
<i>Rubus calycinoides</i> , Creeping Raspberry		•			•	E	6"	18"	S	•	•	•	•
Small Shrubs													
<i>Cornus sericea</i> 'Kelsey', Kelsey dogwood	•	•		•		D	24"	24"	S/Sh	•	•	•	•
<i>Gaultheria shallon</i> , Salal	•	•	•			E	7'	3'	S/Sh	•	•	•	•
<i>Mahonia Nervosa</i> , Dull Oregon Grape	•	•	•			E	24"	24"	S/Sh	•	•	•	•
<i>Polystichum munitum</i> , Sword fern	•	•	•			E	24"	24"	Sh	•	•	•	•
<i>Spirea betulifolia</i> var. <i>lucida</i> , Shinyleaf Spirea	•	•	•			D	36"	24"	S/Sh	•	•	•	•
<i>Spirea densiflora</i> , Subapline spiraea	•	•	•			D	24"	24"	S/Sh	•	•	•	•
<i>Spirea japonica</i> 'Goldmound', Goldmound spiraea	•	•			•	D	24"	18"	S/Sh	•	•	•	•
<i>Spirea japonica</i> 'Magic Carpet', Magic Carpet spiraea	•	•			•	D	18"	24"	S/Sh	•	•	•	•
<i>Symphoricarpos albus</i> , Snowberry	•	•	•			D	6'	3'	S/Sh	•	•	•	•
Large Shrubs													
<i>Cornus sericea</i> , Red-Twig dogwood	•		•			D	10'	6'	S/Sh				
<i>Holodiscus discolor</i> , Oceanspray	•	•	•			D	6'	4'	S/Sh	•	•		•
<i>Lonicera involucrata</i> , Black Twinberry	•	•	•			D	10'	6'	S				
<i>Mahonia aquifolium</i> , Tall Oregon Grape	•	•	•			E	10'	4'	S	•			•
<i>Omleria cerasiformis</i> , Indian plum		•	•			D	6'	6'	S/Sh	•	•		
<i>Philadelphus lewisii</i> , Mock Orange	•	•	•			D	10'	4'	S/Sh	•	•		•
<i>Physocarpus capitatus</i> , Pacific ninebark	•	•	•			D	6'	6'	S/Sh	•			
<i>Ribes sanguineum</i> , Red flowering currant	•	•	•			D	10'	4'	S/Sh	•	•		•
<i>Spirea douglasii</i> , Douglas spiraea	•	•	•			D	7'	4'	S/Sh	•	•		•
<i>Vaccinium ovatum</i> , Evergreen Huckleberry	•	•	•			E	8'	4'	S/Sh	•	•		•
<i>Viburnum ellipticum</i> , Oval-leafed Viburnum	•	•	•			D	12'	4'	S/Sh	•	•		•

Table 2: Stormwater Facility Plant Lists: Swales

Plant Name	Zone		Origin			Type/Size			Context Factors				
	Moisture Zone (A) Uniformly Wet to Moist	Moisture Zone (B) Drier Transitional Area	NW Native	NW Native Cultivar	Non-Native Adapted	(E) Evergreen / (D) Deciduous	Potential Height	Typical On-Center Spacing	(S) Jun / (Sh) Jade	Lined Facility On Top of Utilities	Parking Areas	Streets/ Line of Sight	Adjacent to Buildings
Botanical Name, Common Name													
Onsite Trees (No Trees in Lined Facilities)**													
<i>Acer circinatum</i> , Vine maple	•	•	•			D	15'	12'	S/Sh		•		•
<i>Alnus rubra</i> , Red alder	•	•	•			D	60'	15'	S				
<i>Alnus rhombifolia</i> , White alder	•	•	•			D	60'	15'	S				
<i>Amalanchier alnifolia</i> , Pacific Serviceberry	•	•	•			D	15'	12'	S/Sh	•	•		•
<i>Carpinus caroliniana</i> , American Hornbeam	•				•	D	25'	20'	N/A		•		
<i>Cornus nuttallii</i> , Pacific dogwood	•	•	•			D	20'	12'	S/Sh		•		•
<i>Fraxinus latifolia</i> , Oregon ash	•	•	•			D	30'	20'	S		•		
<i>Malus fusca</i> , Pacific crabapple	•	•	•			D	30'	12'	S/Sh				•
<i>Rhamnus purshiana</i> , Cascara	•	•	•			D	30'	12'	S/Sh				
<i>Sorbus sitchensis</i> , Sitka Mountain Ash	•	•	•			D	15'	12'	S/Sh				
<i>Thuja plicata</i> 'Hogan', Hogan cedar	•	•		•		E	40'	20'	S/Sh		•		

** See City of Albany's recommended street tree list for trees approved for use in streetside post-construction stormwater quality facilities.

Table 3: Stormwater Facility Plant Lists: Dry Ponds

Plant Name	Zone		Origin			Type/Size		Context Factors		
	Moisture Zone (A) Uniformly Wet to Moist	Moisture Zone (B) Drier Transitional Area	NW Native	NW Native Cultivar	Non-Native Adapted	(E)vergreen/(D)eciduous	Potential Height	Typical On-Center Spacing	(S)un / (Sh)ade	Lined Facility/On Top of Utilities
Botanical Name, Common Name										
Herbaceous Plants										
<i>Beckmannia syzigachne</i> , Western Sloughgrass	•		•			D	36"	12"	S	•
<i>Carex densa</i> , Dense sedge	•		•			E	24"	12"	S	•
<i>Carex deweyana</i> , Dewey Sedge		•	•			E	36"	12"	Sh	•
<i>Carex obnupta</i> , Slough sedge	•		•			E	24"	12"	S	•
<i>Carex rosii</i> , Ross's Sedge	•	•	•			D	12"	12"	S	•
<i>Carex tumulicola</i> , Foothill Sedge	•	•	•			E	24"	12"	S	•
<i>Deschampsia caespitosa</i> , Tufted Hairgrass	•	•	•			D	36"	12"	S/Sh	•
<i>Deschampsia elongata</i> , Slender hair grass	•	•	•			E	36"	12"	S	•
<i>Eleocharis ovata</i> , Ovate Spike Rush	•		•			E	30"	12"	S	•
<i>Eleocharis palustris</i> , Creeping Spike Rush	•		•			E	30"	12"	S/Sh	•
<i>Juncus effusus</i> var. <i>pacificus</i> , Pacific Common Rush	•		•			E	36"	12"	S/Sh	•
<i>Juncus ensifolius</i> , Dagger-leaf rush	•		•			D	10"	12"	S	•
<i>Juncus patens</i> , Spreading Rush	•	•	•			E	18"	12"	S/Sh	•
<i>Juncus tenuis</i> , Slender Rush	•		•			E	36"	12"	S/Sh	•
<i>Sagittaria latifolia</i> , Wapato	•		•			D	24"	12"	S/Sh	•
Small Shrubs										
<i>Ceanothus velutinus</i> , Snowbrush		•	•			E	4'	36"	S/SH	•
<i>Cornus sericea</i> 'Kelsey', Kelsey dogwood	•	•		•		D	24"	24"	S	•
<i>Gaultheria shallon</i> , Salal	•	•	•			E	7'	3'	S/Sh	•
<i>Mahonia aquifolium</i> , Oregon Grape		•	•			E	5'	3'	S/Sh	•
<i>Mahonia nervosa</i> , Dull Oregon Grape	•	•	•			E	24"	24"	Sh	•
<i>Mahonia repens</i> , Creeping Oregon Grape	•	•	•			E	18"	18"	S/Sh	•
<i>Polystichum munitum</i> , Sword fern	•	•	•			E	24"	24"	Sh	•
<i>Spirea betulifolia</i> var. <i>lucida</i> , Shinyleaf Spirea	•	•	•			D	36"	24"	S/Sh	•
<i>Spirea densiflora</i> , Subapline spiraea	•	•	•			D	24"	24"	S/Sh	•
<i>Symphoricarpos albus</i> , Snowberry	•	•	•			D	6'	3'	S/Sh	•
<i>Vaccinium ovatum</i> , Evergreen Huckleberry	•	•	•			E	36"	36"	S/Sh	•
Large Shrubs										
<i>Arbutus unedo</i> , Strawberry Tree		•			•	E	10'	10'	S/Sh	•
<i>Amelanchier alnifolia</i> , Western Serviceberry		•	•			D	20'	10'	S/Sh	•
<i>Ceanothus sanguineus</i> , Oregon Redstem Ceanothus		•	•			D	7'	4'	S	•
<i>Ceanothus thyrsiflorus</i> , Blueblossom		•	•			E	6'	6'	S/Sh	•
<i>Cornus sericea</i> , Red-Twig dogwood	•		•			D	10'	6'	S/Sh	
<i>Holodiscus discolor</i> , Oceanspray	•	•	•			D	7'	4'	S/Sh	•
<i>Lonicera involucrata</i> , Black Twinberry	•	•	•			D	10'	4'	S/Sh	
<i>Mahonia aquifolium</i> , Tall Oregon Grape	•	•	•			E	10'	4'	S	•
<i>Omleria cerasiformis</i> , Indian plum		•	•			D	6'	6'	S/Sh	•
<i>Philadelphus lewisii</i> , Mock Orange	•	•	•			D	10'	4'	S/Sh	•
<i>Physocarpus capitatus</i> , Pacific ninebark	•		•			D	6'	6'	S/Sh	
<i>Ribes sanguineum</i> , Red flowering currant	•	•	•			D	10'	4'	S/Sh	•
<i>Spirea douglasii</i> , Douglas spiraea	•	•	•			D	7'	4'	S/Sh	•
<i>Vaccinium ovatum</i> , Evergreen Huckleberry	•	•	•			E	8'	4'	S/Sh	•
<i>Viburnum edule</i> , Highbush Cranberry	•		•			D	6'	4'	S/Sh	
<i>Viburnum ellipticum</i> , Oval-leafed Viburnum	•	•	•			D	12'	4'	S/Sh	•

Table 3: Stormwater Facility Plant Lists: Dry Ponds

Plant Name	Zone		Origin			Type/Size		Context Factors		
	Moisture Zone (A) Uniformly Wet to Moist	Moisture Zone (B) Drier Transitional Area	NW Native	NW Native Cultivar	Non-Native Adapted	(E)vergreen/(D)eciduous	Potential Height	Typical On-Center Spacing	(S)un / (Sh)ade	Lined Facility/On Top of Utilities
Botanical Name, Common Name										
Trees										
<i>Acer circinatum</i> , Vine maple	N/A	•	•			D	15'	12'	N/A	•
<i>Alnus rhombafolia</i> , White alder	N/A	•	•			D	60'	15'	N/A	
<i>Alnus rubra</i> , Red alder	N/A	•	•			D	60'	15'	N/A	
<i>Arbutus menziesii</i> , Madrone	N/A	•	•			E	35'	20'	N/A	
<i>Cornus nuttalii</i> , Pacific dogwood	N/A	•	•			D	20'	12'	N/A	•
<i>Fraxinus latifolia</i> , Oregon ash	N/A	•	•			D	30'	20'	N/A	
<i>Malus fusca</i> , Pacific crabapple	N/A	•	•			D	30'	12'	N/A	•
<i>Rhamnus purshiana</i> , Cascara	N/A	•	•			D	30'	12'	N/A	•
<i>Sorbus sitchensis</i> , Sitka Mountain Ash	N/A	•	•			D	20'	12'	S/Sh	

** See City of Albany’s recommended street tree list for trees approved for use in streetside post-construction stormwater quality facilities.

PLANT DIAGRAM AND LEGEND 1

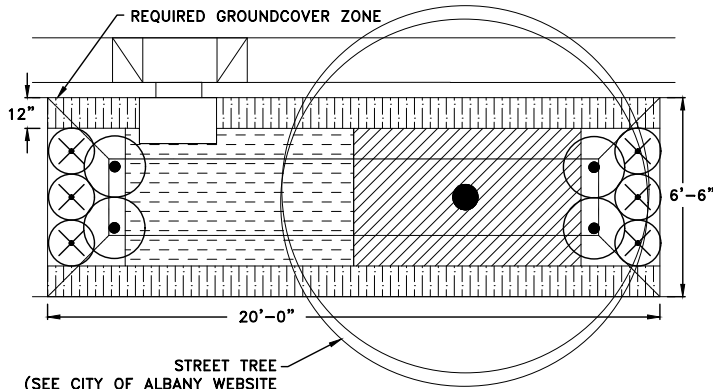

STREET TREE
(SEE CITY OF ALBANY WEBSITE
FOR APPROVED TREE LIST FOR
STORMWATER FACILITIES)

Symbol	Botanical name COMMON NAME	E/D	O.C.	QTY
ZONE A				
[Hatched pattern]	<i>Carex obnupta</i> SLOUGH SEDGE	E	12"	32
[Diagonal hatched pattern]	<i>Juncus patens</i> 'Elk Blue' ELK BLUE GRAY RUSH	E	12"	33
[Circle with dot]	<i>Spiraea japonica</i> 'Magic Carpet' MAGIC CARPET SPIRAEA	D	24"	4
ZONE B				
[Vertical hatched pattern]	<i>Fragaria chiloensis</i> COASTAL STRAWBERRY	E	12"	37
[Circle with cross]	<i>Mahonia repens</i> CREEPING OREGON GRAPE	E	18"	6

PLANT DIAGRAM AND LEGEND 2

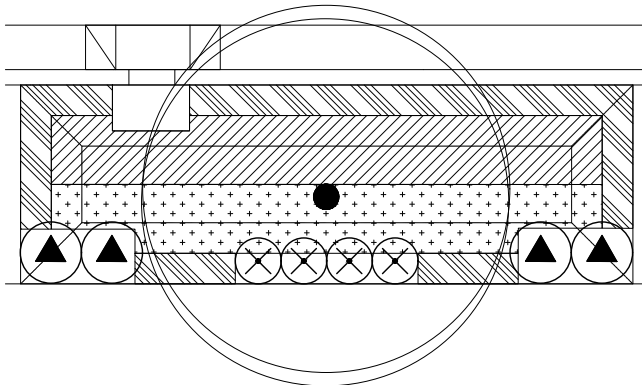

Symbol	Botanical name COMMON NAME	E/D	O.C.	QTY
ZONE A				
[Star pattern]	<i>Carex morrowii</i> 'Variegata' VARIEGATED JAPANESE SEDGE	E	12"	36
[Diagonal hatched pattern]	<i>Juncus patens</i> 'Elk Blue' ELK BLUE GRAY RUSH	E	12"	39
ZONE B				
[Diagonal hatched pattern]	<i>Rubus calycinoides</i> CREEPING RASPBERRY	E	18"	31
[Circle with cross]	<i>Mahonia repens</i> CREEPING OREGON GRAPE	E	18"	4
[Circle with triangle]	<i>Cornus sericea</i> 'Kelseyi' Kelsey Dogwood	D	24"	4

PLANT DIAGRAM AND LEGEND 3

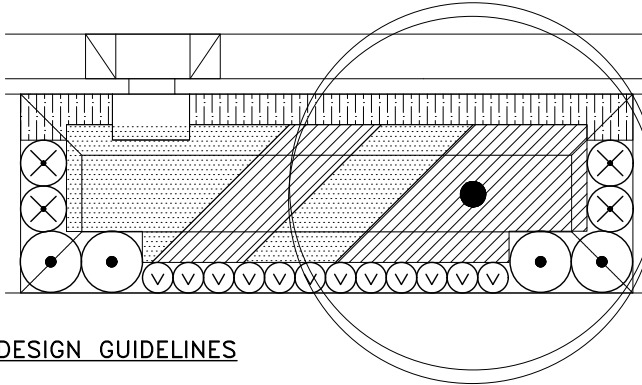

Symbol	Botanical name COMMON NAME	E/D	O.C.	QTY
ZONE A				
[Dotted pattern]	<i>Deschampsia elongata</i> SLENDER HAIR GRASS	E	12"	34
[Diagonal hatched pattern]	<i>Juncus patens</i> 'Elk Blue' ELK BLUE GRAY RUSH	E	12"	38
ZONE B				
[Vertical hatched pattern]	<i>Fragaria chiloensis</i> COASTAL STRAWBERRY	E	12"	19
[Circle with inverted triangle]	<i>Elymus glaucus</i> BLUE WILD RYE	E	12"	12
[Circle with cross]	<i>Mahonia repens</i> CREEPING OREGON GRAPE	E	18"	4
[Circle with dot]	<i>Spiraea japonica</i> 'Magic Carpet' MAGIC CARPET SPIRAEA	D	24"	4

DESIGN GUIDELINES

1. These are example planting diagrams approved by the City of Albany. Choose a planting diagram and alter it to your design. Other planting designs may be approved.
2. See Engineering Design Standards text for landscape requirements.
3. See Plant Matrix for typical plant spacing.
4. Planting table required per Engineering Design Standards text. Planting legends shown here do not include all required information for planting tables.

**CITY OF ALBANY, OREGON
PUBLIC WORKS DEPARTMENT**

**SHALLOW SWALE
EXAMPLE PLANTING DIAGRAMS**

NO SCALE

OCTOBER 2019

PLANT DIAGRAM AND LEGEND 1

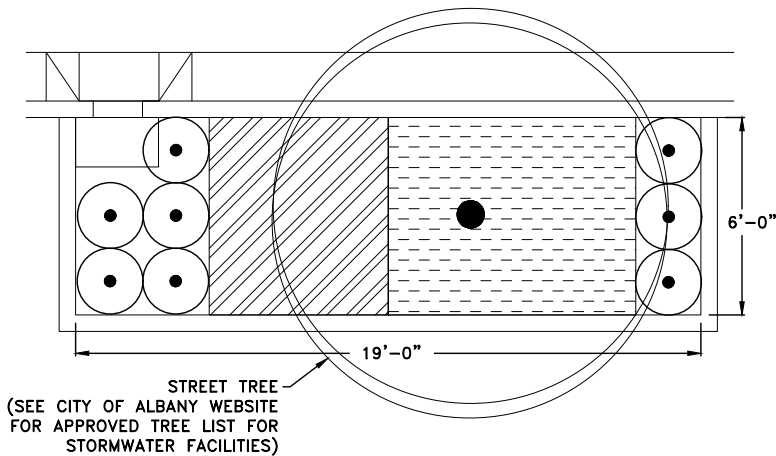

Symbol	Botanical name COMMON NAME	E/D	O.C.	QTY
	<i>Carex obnupta</i> SLOUGH SEDGE	E	12"	45
	<i>Juncus ensifolius</i> DAGGER-LEAF RUSH	D	12"	33
	<i>Cornus sericea 'Kelsey'</i> KELSEY DOGWOOD	D	24"	8

PLANT DIAGRAM AND LEGEND 2

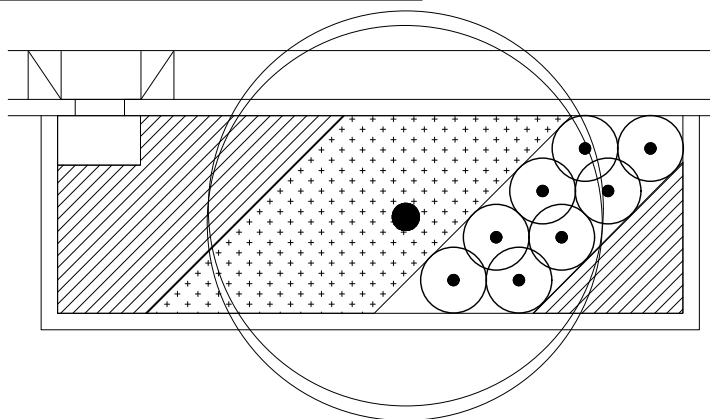

Symbol	Botanical name COMMON NAME	E/D	O.C.	QTY
	<i>Carex morrowii 'Variegata'</i> VARIEGATED JAPANESE SEDGE	E	12"	43
	<i>Juncus patens 'Elk Blue'</i> ELK BLUE GRAY RUSH	E	12"	40
	<i>Cornus sericea 'Kelsey'</i> KELSEY DOGWOOD	D	24"	8

PLANT DIAGRAM AND LEGEND 3

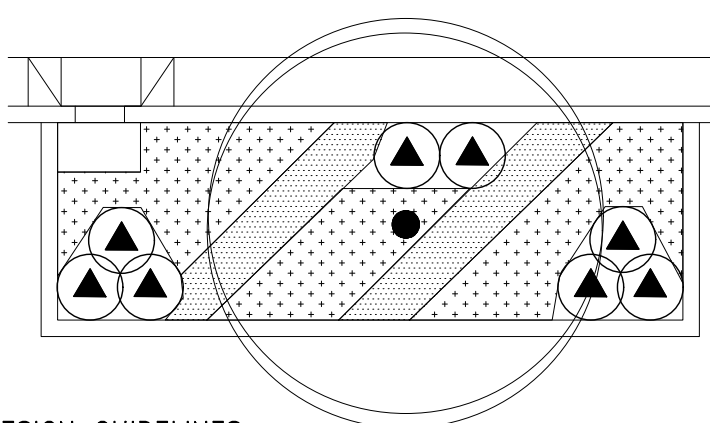

Symbol	Botanical name COMMON NAME	E/D	O.C.	QTY
	<i>Carex morrowii 'Variegata'</i> VARIEGATED JAPANESE SEDGE	E	12"	56
	<i>Deschampsia elongata</i> SLENDER HAIR GRASS	E	12"	26
	<i>Mahonia aquifolium</i> Tall Oregon Grape	E	4'	8

DESIGN GUIDELINES

1. These are example planting diagrams approved by the City of Albany. Choose a planting diagram and alter it to your design. Other planting designs may be approved.
2. See Engineering Design Standards text for landscape requirements.
3. See Plant Matrix for typical plant spacing.
4. Planting table required per Engineering Design Standards text. Planting legends shown here do not include all required information for planting tables.

CITY OF ALBANY, OREGON PUBLIC WORKS DEPARTMENT	
6' PLANTER EXAMPLE PLANTING DIAGRAMS	
NO SCALE	OCTOBER 2019

PLANT DIAGRAM AND LEGEND 1

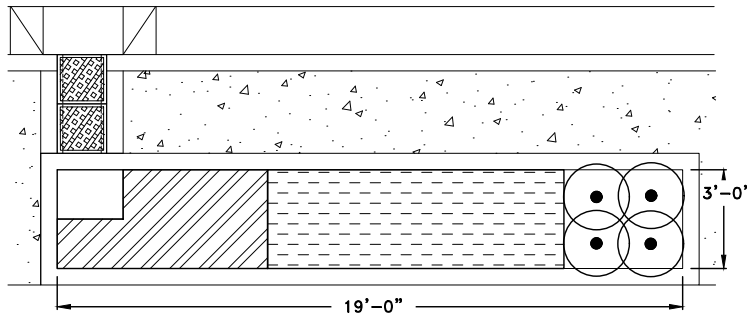

Symbol	Botanical name COMMON NAME	E/D	O.C.	QTY
	<i>Carex obnupta</i> SLOUGH SEDGE	E	12"	27
	<i>Juncus ensifolius</i> DAGGER-LEAF RUSH	D	12"	16
	<i>Cornus sericea</i> 'Kelsey' KELSEY DOGWOOD	D	24"	4

PLANT DIAGRAM AND LEGEND 2

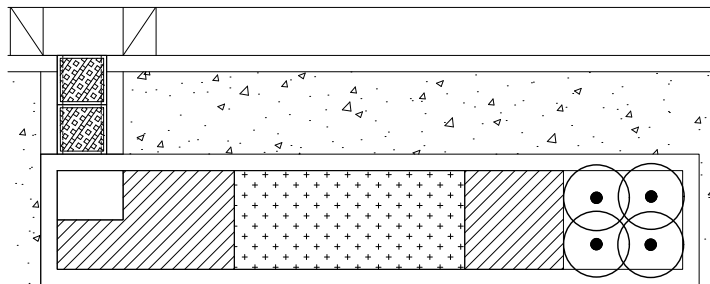

Symbol	Botanical name COMMON NAME	E/D	O.C.	QTY
	<i>Carex morrowii</i> 'Variegata' VARIEGATED JAPANESE SEDGE	E	12"	21
	<i>Juncus patens</i> 'Elk Blue' ELK BLUE GRAY RUSH	E	12"	22
	<i>Cornus sericea</i> 'Kelsey' KELSEY DOGWOOD	D	24"	4

PLANT DIAGRAM AND LEGEND 3

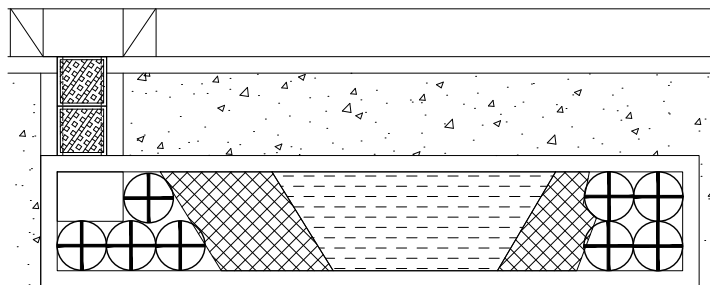

Symbol	Botanical name COMMON NAME	E/D	O.C.	QTY
	<i>Carex obnupta</i> SLOUGH SEDGE	E	12"	20
	<i>Juncus patens</i> SPREADING RUSH	E	12"	14
	<i>Spiraea japonica</i> 'Goldmound' GOLDMOUND SPIRAEA	D	18"	8

DESIGN GUIDELINES

1. These are example planting diagrams approved by the City of Albany. Choose a planting diagram and alter it to your design. Other planting designs may be approved.
2. See Engineering Design Standards text for landscape requirements.
3. See Plant Matrix for typical plant spacing.
4. Planting table required per Engineering Design Standards text. Planting legends shown here do not include all required information for planting tables.

**CITY OF ALBANY, OREGON
PUBLIC WORKS DEPARTMENT**

**PLANTER W/ STEP OUT
EXAMPLE PLANTING DIAGRAMS**

NO SCALE

OCTOBER 2019

PLANT DIAGRAM AND LEGEND 1

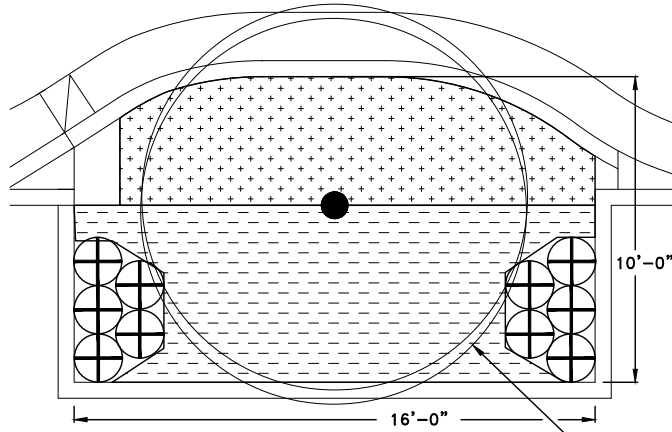

Symbol	Botanical name COMMON NAME	E/D	O.C.	QTY
	<i>Carex obnupta</i> SLOUGH SEDGE	E	12"	68
	<i>Carex morrowii</i> 'Variegata' VARIEGATED JAPANESE SEDGE	D	12"	52
	<i>Spirea japonica</i> "Goldmound" GOLDMOUND SPIREA	D	18"	10

STREET TREE
(SEE CITY OF ALBANY WEBSITE
FOR APPROVED TREE LIST FOR
STORMWATER FACILITIES)

PLANTING DIAGRAM AND LEGEND 2

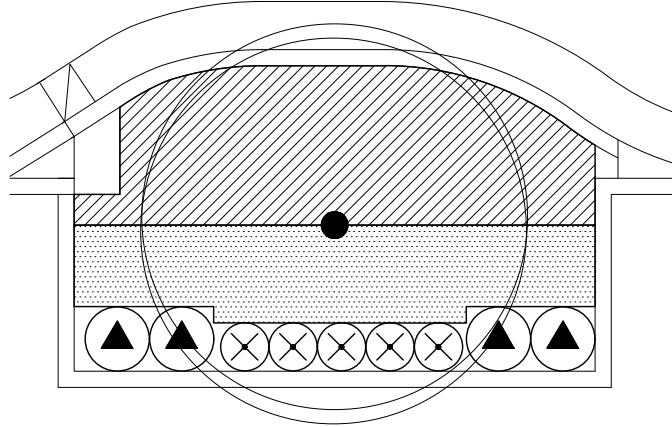

Symbol	Botanical name COMMON NAME	E/D	O.C.	QTY
	<i>Deschampsia elongata</i> SLENDER HAIR GRASS	E	12"	47
	<i>Juncus patens</i> 'Elk Blue' ELK BLUE GRAY RUSH	E	12"	68
	<i>Mahonia repens</i> CREEPING OREGON GRAPE	E	18"	5
	<i>Gaultheria shallon</i> Salal	E	36"	4

PLANTING DIAGRAM AND LEGEND 3

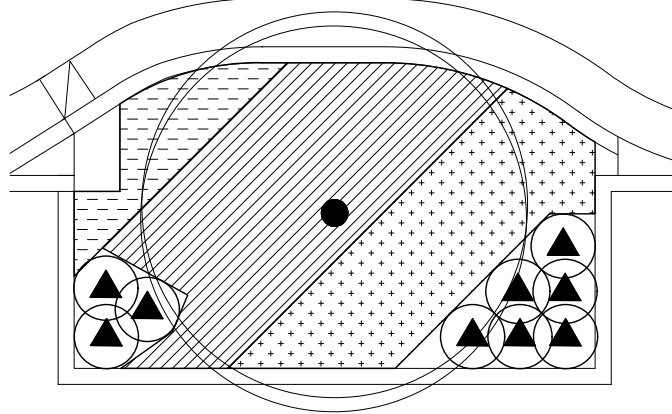

Symbol	Botanical name COMMON NAME	E/D	O.C.	QTY
	<i>Carex obnupta</i> SLOUGH SEDGE	E	12"	15
	<i>Carex morrowii</i> 'Variegata' VARIEGATED JAPANESE SEDGE	E	12"	41
	<i>Juncus Patens</i> "Elk Blue" ELK BLUE GRAY RUSH	E	12"	59
	<i>Gaultheria shallon</i> Salal	E	36"	9

DESIGN GUIDELINES

1. These are example planting diagrams approved by the City of Albany. Choose a planting diagram and alter it to your design. Other planting designs may be approved.
2. See Engineering Design Standards text for landscape requirements.
3. See Plant Matrix for typical plant spacing.
4. Planting table required per Engineering Design Standards text. Planting legends shown here do not include all required information for planting tables.

<p>CITY OF ALBANY, OREGON PUBLIC WORKS DEPARTMENT</p>	
<p>MIDBLOCK CURB EXTENSION EXAMPLE PLANTING DIAGRAMS</p>	
<p>NO SCALE</p>	<p>OCTOBER 2019</p>

PLANT DIAGRAM AND LEGEND 1

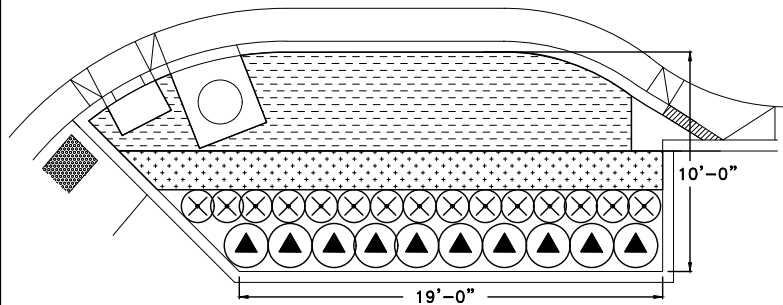

Symbol	Botanical name COMMON NAME	E/D	O.C.	QTY
[Wavy pattern]	Carex obnupta SLOUGH SEDGE	E	12"	82
[Dotted pattern]	Carex morrowii 'Variegata' VARIEGATED JAPANESE SEDGE	E	12"	42
[Circle with X]	Mahonia repens CREEPING OREGON GRAPE	E	18"	15
[Triangle in circle]	Cornus sericea 'Kelseyi' KELSEY DOGWOOD	D	24"	10

PLANT DIAGRAM AND LEGEND 2

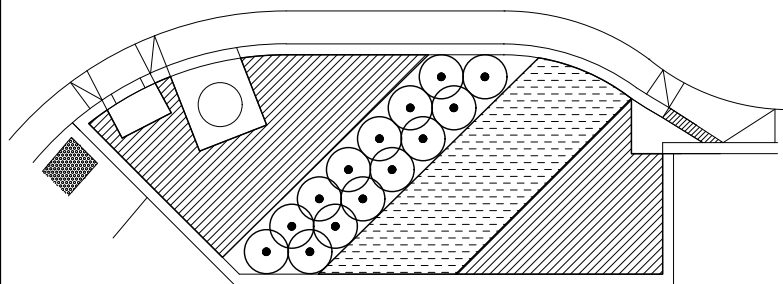

Symbol	Botanical name COMMON NAME	E/D	O.C.	QTY
[Wavy pattern]	Carex obnupta SLOUGH SEDGE	E	12"	56
[Diagonal hatching]	Juncus patens 'Elk Blue' ELK BLUE GRAY RUSH	E	12"	96
[Circle with dot]	Cornus sericea 'Kelseyi' KELSEY DOGWOOD	D	24"	14

PLANT DIAGRAM AND LEGEND 3

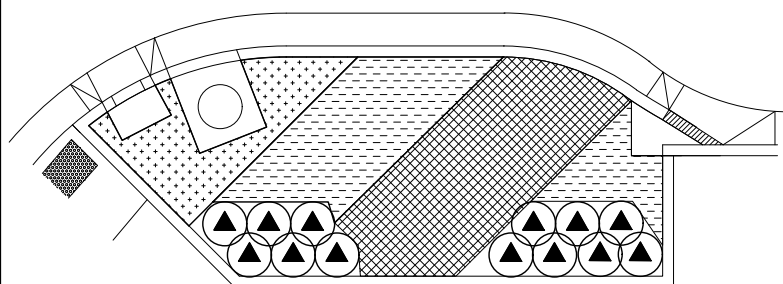

Symbol	Botanical name COMMON NAME	E/D	O.C.	QTY
[Wavy pattern]	Carex obnupta SLOUGH SEDGE	E	12"	58
[Dotted pattern]	Carex morrowii 'Variegata' VARIEGATED JAPANESE SEDGE	E	12"	30
[Cross-hatching]	Juncus patens SPREADING RUSH	E	12"	68
[Triangle in circle]	Cornus sericea 'Kelseyi' KELSEY DOGWOOD	D	24"	13

DESIGN GUIDELINES

1. These are example planting diagrams approved by the City of Albany. Choose a planting diagram and alter it to your design. Other planting designs may be approved.
2. See Engineering Design Standards text for landscape requirements.
3. See Plant Matrix for typical plant spacing.
4. Planting table required per Engineering Design Standards text. Planting legends shown here do not include all required information for planting tables.

CITY OF ALBANY, OREGON
PUBLIC WORKS DEPARTMENT

INTERSECTION CURB EXTENSION
EXAMPLE PLANTING DIAGRAMS

NO SCALE

OCTOBER 2019

**PRIVATE STORMWATER FACILITIES
OPERATIONS AND MAINTENANCE AGREEMENT**

This Agreement is made and entered into this _____ day of _____ 20____, by and between City of Albany (City) and _____ (Owner).

RECITALS

- A. Owner has developed or will develop the private stormwater facilities (Facilities) listed below and shown on attached, and/or referenced, as-built construction drawings for _____ in order to satisfy the requirements of Chapter 12.45 of the Albany Municipal Code.
- B. The Facilities enable development of property while mitigating the impacts of additional surface water and pollutants associated with stormwater runoff prior to discharge from the property to the public stormwater system or waters of the state. The consideration for this Agreement is connection to the public stormwater system or waters of the state.
- C. The property benefited by the Facilities and subject to the obligation of this Agreement is described with the legal description below or in Exhibit A (Property) attached hereto and incorporated by reference.
- D. The Facilities have been designed by a registered design professional and constructed to accommodate the anticipated volume of runoff and to detain and treat runoff in accordance with Albany's Municipal Code, Development Code, Engineering standards, and Construction Specifications, as applicable.
- E. For the Facilities to function properly over time, they must be maintained in accordance with the attached Operations and Maintenance (O&M) Plan.
- F. The O&M Plan represents current best management practices for O&M activities. It is acknowledged that best management practices for O&M activities may change over time.
- G. Even with routine maintenance conducted through the O&M Plan, over time, there is potential for the Facilities to lose treatment capacity through extended filtration and absorption of pollutants.
- H. Failure to inspect and maintain the Facilities can result in an unacceptable impact to the public stormwater system and/or waters of the state.

NOW, THEREFORE, it is agreed by and between the parties as follows:

- 1. **INCORPORATION OF RECITALS** The recitals above are acknowledged and agreed to by all parties.
- 2. **CONSIDERATION** Owner undertakes the obligations set forth herein in consideration of development approval granted by the City and acknowledges that said consideration is adequate to support these obligations.
- 3. **PARTIES** The terms of this agreement apply to the named parties, their agents, contractors, successors, and assigns.
- 4. **O&M PLAN** As best management practices for O&M activities change over time the owner will be bound to the most current standard operation and maintenance requirements set forth in the most current version of the City's Engineering Standards or like requirements. It is the City's responsibility to notify the owner of any required modifications to current practices.

5. **TERM** Owners obligations hereunder are perpetual and may only be modified or eliminated by amendment as described herein.
6. **OWNER INSPECTIONS** Owner agrees to operate, inspect and maintain each Facility in accordance with design parameters and the O&M Plan, attached hereto as Exhibit B and incorporated by reference. Owner shall retain a copy of this agreement, the O&M plan, and applicable as-built drawings on site. The owner shall also maintain a log of all inspection activities on site. The agreements, O&M plan, as-builts, and maintenance log shall be available to the City upon request or during City inspections.
7. **OWNER NOTICE OF FACILITY FAILURE** Owner shall provide notice to the City if Facilities fail to function as designed. Notice shall be provided within ten (10) days of identifying the failure. Additionally, Owner shall provide immediate notice to the City of any potentially damaging discharge or spill to the Facilities, public storm drain system, or water of the state.
8. **DEFICIENCIES** All aspects in which the Facilities fail to satisfy the O&M Plan, and/or provide the level of treatment intended with their design, shall be noted as “Deficiencies”.
9. **OWNER CORRECTIONS** All Deficiencies shall be corrected at Owner’s expense within thirty (30) days after completion of the inspection. In addition to the maintenance practices identified in the O&M Plan, corrections may include replacement of treatment soil, vegetation, drain rock, and/or other system components as applicable if the City determines that the Facility no longer provides the designed level of treatment. If more than 30 days is reasonably needed to correct a Deficiency, Owner shall have a reasonable period to correct the Deficiency so long as the correction is commenced within the 30-day period and is diligently prosecuted to completion.
10. **CITY INSPECTIONS** Owner grants City right of entry to inspect the Facilities. City will endeavor to give ten (10) days prior notice to Owner, except that no notice shall be required in case of an emergency. Inspections are not limited to the activities identified in the O&M plan and may include testing as necessary to determine if the Facilities are retaining their designed treatment capacity. City shall determine whether Deficiencies need to be corrected. Owner will be notified in writing of the Deficiencies and shall make corrections within 30 days of the date of the notice.
11. **RIGHT OF ENTRY** Owner hereby authorizes and consents to the exercise of all entry authority granted to the City pursuant to AMC 12.45.150 as it now exists, or may hereafter be amended, to permit inspections and testing of the private post-construction stormwater quality facilities. The same rights of entry shall apply to City Corrections.
12. **CITY CORRECTIONS** If correction of all Owner or City identified Deficiencies is not completed within thirty (30) days (or the “reasonable period” as described in Section 9, whichever is larger) after Owner’s inspection or City notice, City shall have the right to have any Deficiencies corrected. City shall have access to the Facilities for the purpose of correcting such Deficiencies. Owner shall pay all costs reasonably incurred by City for work performed to correct the Deficiencies (City Correction Costs) following Owner’s failure to correct any Deficiencies in the Facilities. Owner shall pay City the City Correction Costs within thirty (30) days of the date of the invoice. Owner understands and agrees that upon non-payment, City Correction Costs shall be secured by a lien on the Property for the City Correction Cost plus interest and penalties which lien, shall take priority over all other liens and encumbrances to the maximum extent permitted by law. City Correction Costs are defined as all City expenses incurred in taking the corrective actions authorized herein. These costs include, but are not limited to, all amounts paid, or to be paid, to third party contractors as well as all direct and

indirect City costs including, but not limited to, labor, benefits, equipment, engineering, administrative, and legal costs. Costs will be determined using the City’s current cost accounting methodology.

- 13. EMERGENCY MEASURES If at any time City reasonably determines that the Facilities create any imminent threat to public health, safety or welfare, City is hereby granted immediate right of access and may immediately and without prior notice to Owner take measures reasonably designed to remedy the threat. City shall provide notice of the threat and the measures taken to Owner as soon as reasonably practicable, and charge Owner for the cost of these corrective measures.
- 14. COVENANT RUNNING WITH THE LAND The terms of this agreement shall be recorded with the appropriate records department of the County in which the property is located and shall be a covenant running with the land and binding on all owners of the Property present and future, and their heirs, successors and assigns. Owner shall notify City of any change in property ownership and/or change in the owner representative designated to receive notices in Section 21 below.
- 15. AMENDMENTS The terms of this Agreement may be amended only by mutual agreement of the parties. Any amendments shall be in writing, shall refer specifically to this Agreement, and shall be valid only when executed by the owners of the Property, City and recorded in the Official Records of the county where the Property is located.
- 16. REMEDIES CUMULATIVE Remedies provided herein for breach of this agreement are cumulative and in addition to any and all other civil and criminal remedies.
- 17. VENUE AND ATTORNEY FEES Any litigation concerning this Agreement shall be brought in the Circuit Court of the State of Oregon for Linn County and the prevailing party shall be entitled to recover all costs, including reasonable attorney’s fees as may be determined by the court, including those on appeal.
- 18. SEVERABILITY The invalidity of any section, clause, sentence, or provision of this Agreement shall not affect the validity of any other part of this Agreement, which can be given effect without such invalid part or parts.
- 19. AMBIGUITIES in this agreement, if any, shall not be resolved against the drafter.
- 20. COMPLETE INTEGRATION This Agreement is a complete integration of all of the parties’ understandings and expectations of the other with regard to the subject of this Agreement. Prior discussions or representations which are not included in this Agreement are of no effect.
- 21. NOTICES Any notice required or permitted under this Agreement shall be given when actually delivered within three (3) business days following deposit in the United States Mail, certified mail, and addressed as follows:

A. To the Owner:

B. To the City: City of Albany, Public Works Department
Attn: Public Works Director
P.O. Box 490
Albany, OR 97321

IN WITNESS WHEREOF, Owner has signed this Agreement.

OWNER:

Signature: _____

Name: _____

Title: _____

Address: _____

[Use this notary block if Owner is an individual.]

STATE OF _____

County of _____

This instrument was acknowledged before me this _____ day
of _____, 20____.

Notary Public

[Use this notary block only if Owner is an entity.]

STATE OF _____

County of _____

This instrument was acknowledged before me this _____ day of _____,
20____, by

_____ (name of person) as _____ (title) of
_____ (name of entity).

Notary Public

CITY OF ALBANY:

Public Works Director, or designee

Date

Stormwater Quality Facilities O&M Checklists

The following checklists provide guidance for operating, inspecting, troubleshooting, and maintaining stormwater quality facilities in a post-construction setting. The required and recommended inspection frequency for inspections is also included.

O&M checklists are provided for the following types of facilities:

- Planter/Curb Extension/Swale
- Pervious Pavement
- Green Roof
- Water Quality (Pretreatment) Manhole
- Dry Ponds

Planter/Curb Extension/Swale – O&M Checklist

These vegetated post-construction stormwater quality facilities are designed to accept stormwater runoff from adjacent impervious surfaces. They remove pollutants by filtering runoff through vegetation and soil media. Water should drain through the facility within 24 hrs after a storm event. This checklist describes required and recommended inspection and maintenance activities to provide for proper facility function.

Inspection Timing	Facility Feature	Problem	Conditions to Check for	Maintenance Practices
Required: Annually <i>Recommended: Monthly from November-April and after any large storm (e.g., 1 inch in 24 hrs)</i>	General	Sediment accumulation in treatment area	Sediment depth exceeds 2 ins.	Remove sediment from vegetated treatment area. Rake to ensure facility is level across bottom and water drains freely through soil media. Replace soil media or vegetation as needed
Required: Annually <i>Recommended: Monthly from November-April and after any large storm (1 inch in 24 hrs)</i>	General	Erosion scouring	Eroded or scoured facility bottom due to flow channelization, or higher flows	Repair ruts or bare areas by filling with facility soil media; repair or add splash blocks or rock energy dissipaters at curb and pipe inlets; regrade and replant large bare areas; use erosion control measures as needed
Required: Annually <i>Recommended: Monthly from November-April and after any large storm (1 inch in 24 hrs)</i>	General	Standing water	Standing water in the facility between storms that does not drain freely; no standing water should exist within 48 hrs after any large storm (1 inch in 24 hrs or larger)	Remove sediment or trash blockages and rake soil to clear of debris; remove sediment from clean-outs and clear perforated underdrains as needed
Required: Annually <i>Recommended: Monthly</i>	General	Rodents	Evidence of rodents or water piping through facility via rodent holes	Repair facility, fill rodent holes, and remove rodents
Required: Annually <i>Recommended: Monthly during growing season</i>	General	Insects	Insects such as wasps and hornets interfere with maintenance activities	Remove harmful insects and insect nests as needed
Required: Annually <i>Recommended: Monthly and after any large storm (1 inch in 24 hrs)</i>	General	Trash and debris	Visual evidence of trash, debris or dumping	Remove trash and debris from facility
Required: Annually <i>Recommended: Monthly from November-April and after any large storm (e.g., 1 inch in 24 hrs)</i>	General	Contamination and pollution	Any evidence of spills or excess oil, gasoline, contaminants, or other pollutants	Remove/cleanup contaminants. Coordinate removal/cleanup with City of Albany Public Works
Required: Annually <i>Recommended: Annually and after any large storm (1 inch in 24 hrs)</i>	General	Facility malfunction; lack of drainage even after maintenance for sediment or standing water	Facility is not receiving flow and/or draining properly; structural malfunction or broken, misaligned or missing parts have created a safety, drainage, and/or other design problem	Repair or replace entire facility or broken/non-functioning elements to meet design standards and plans

Planter/Curb Extension/Swale – O&M Checklist (continued)

Inspection Timing	Facility Feature	Problem	Conditions to Check for	Maintenance Practices
Required: Annually <i>Recommended: Monthly and after any large storm (1 inch in 24 hrs)</i>	Inlets/Outlets	Obstructed or non-working inlet/outlet	Inlet/outlet areas clogged with sediment, vegetation or debris; sediment trap, if present, is half or more full; overflow or clean-out pipes are damaged or parts are missing	Remove material to clear inlet and outlet areas, inflow pipes or downspouts, and sediment traps. Clear perforated drain pipe as needed. Repair or replace drain pipe, cap, grate structure or other elements as needed.
Required: Annually <i>Recommended: Monthly from November-June</i>	Inlets/Outlets	Vegetation blockages	Vegetation blocking more than 10% of the inlet or outlet opening	Trim or remove excess vegetation and soil. No vegetation should block flow at inlets/outlets or overflows. If removing excess vegetation, protect area from erosion.
Required: Annually <i>Recommended: Monthly and after any large storm (1 inch in 24 hrs)</i>	Check Dams	Erosion, scouring, flow undermining	Scoured flow paths around sides or from underneath check dams; wood rot or holes; check dam is properly attached, aligned and secure; ballast rock on downstream side is in place	Repair ruts and scour areas with compost or facility soil media; Replace ballast rock; Repair or replace check dam as needed.
Required: Annually <i>Recommended: Monthly</i>	Vegetation	Dead or Stressed vegetation and/or poor vegetation coverage	Vegetation is dead, stressed, sparse, bare or soil eroded in more than 10% of the facility	Determine cause of poor growth and correct the condition; replant with containerized plants as needed to meet design density standards. Replant per the approved planting plan if available.
Required: Annually <i>Recommended: Monthly during growing season</i>	Vegetation	Invasive vegetation and weeds	Nuisance weeds present. Invasive vegetation is present, including but not limited to the following: Himalayan Blackberry; Reed Canary Grass; Teasel English Ivy; Nightshade; Clematis; Cattail Thistle; Scotch Broom	Remove excessive weeds and invasive vegetation.
Required: Annually <i>Recommended: Monthly during growing season</i>	Vegetation	Excessive shading	Vegetation growth is poor because sunlight does not reach facility	Remove brushy vegetation as needed; re-plant with shade tolerant plants from City facility plant lists as needed.
Required: Annually <i>Recommended: Monthly from November-April and after any large storm (e.g., 1 inch in 24 hrs)</i>	Liner (If Applicable)	Exposed or damaged liner, leaks from lined facility	Exposed or damaged liner with evidence of, or potential for damage or leakage	Repair or replace liner and restore cover material.
Required: Annually <i>Recommended: Annually</i>	Signage	No parking signs or paint striping is not present or visually clear (only where required on project plans)	Signs are missing, bent or vandalized. Paint striping on street-side curb is faded or missing	Repair/replace signs and re-paint striping as needed.

Note: No chemical control measures such as herbicides, insecticides, pesticides, fertilizers, and rodenticides shall be used in post-construction stormwater quality facilities without prior approval from the City of Albany.

Pervious Pavement – O&M Checklist

These facilities are impervious area reduction measures designed with a porous surface and an underlying stone layer that temporarily stores rainwater that percolates through the surface before infiltrating into the subsoil or being collected in underlying drain pipes and being discharged to the stormwater system. This checklist describes required and recommended inspection and maintenance activities to provide for proper facility function. For manufactured paver systems, the manufacturer’s maintenance recommendations shall also be followed.

Inspection Timing	Facility Feature	Problem	Conditions to Check for	Maintenance Practices
Required: Bi-annually <i>Recommended: Twice per year and after large storms (1 inch in 24 hrs)</i>	Pavement Surface	Sediment and debris deposits, potentially reducing infiltration capacity	Sediment and debris deposits across surface	Sweep with regenerative air sweeper at least twice per year as a preventive measure against clogging.
Required: Annually <i>Recommended: Monthly for areas near landscaping, adjacent to impervious areas, or in pathways of dirty vehicles</i>	Pavement Surface	Sediment and debris deposits, water infiltrates unevenly across surface or ponds in low areas	Clogged surface, water ponding, and/or water infiltrating unevenly across surface	Concrete or asphalt pervious pavement: Power wash; paver systems: unclog with vacuum sweeper truck or method per manufacturer’s recommendations do not use surfactants; use inlet protection measures to collect debris and filter power wash runoff.
Required: Annually <i>Recommended: Annually</i>	Structural components	Cracked or moving edge constraints; cracked or settled pavement	Cracked or moving edge constraints, or cracked or settled pavement that affects overall performance	Repair all cracks, settlement or other defects that affect performance of facility per design professional’s or manufacturers’ specifications.
Required: Annually during fall <i>Recommended: Monthly during the Fall</i>	General	Leaf litter deposition on surface	Leaf litter that could affect stormwater infiltration through pavement	Sweep leaf litter and sediment to prevent surface clogging and ponding.
Required: Annually <i>Recommended: Monthly during growing season</i>	Vegetation	Weeds	Weeds that cover 10% of the surface area	Remove weeds by hand, power washing, or other approved method; use inlet protection measures if power washing.
Required: Annually <i>Recommended: Annually and after power washing, vacuum sweeping, and weeding)</i>	Filter medium between pavers	Aggregate loss in pavers	Settling of pavers or lack of aggregate around pavers	Reset pavers and replace pore space with aggregate from original design.

Note: No chemical control measures such as herbicides, insecticides, pesticides, fertilizers, and rodenticides shall be used in post-construction stormwater quality facilities without prior approval from the City of Albany.

Green Roof – O&M Checklist

These facilities are impervious area reduction measures and are lined and vegetated rooftop systems designed to intercept rainfall and reduce runoff - with excess flows directed to downspout drains. This checklist describes required and recommended inspection and maintenance activities to provide for proper facility function. System suppliers and manufacturer’s recommendations shall also be followed for proper maintenance.

Inspection Timing	Facility Feature	Problem	Conditions to Check For	Maintenance Practices
Required: Two times per year <i>Recommended: Monthly November-April and after large storms (1 inch in 24 hrs).</i>	Green Roof structural components	Standing water, super saturated soil	Clogged drain or compacted soil	Clear drains; remove organics and other debris from drain; loosen compacted soil and amend.
Required: Annually <i>Recommended: Annually and after large storms (1 inch in 24 hrs).</i>	Structural components	Leaks in roof	Tears or perforation of membrane	Repair immediately. Contact manufacturer for repair or replacement.
Required: Annually <i>Recommended: During Fall and Spring.</i>	Vegetation	Dead or stressed vegetation	Healthy vegetation should cover 90% of facility	Replant per original planting plan; irrigate as needed.
Required: Annually <i>Recommended: During Fall and Spring.</i>	Vegetation	Dry grass or plants that may present a fire hazard	Overgrown areas, dry grasses, dead branches and leaves	Prune grass and plantings; remove clippings & debris.
Required: Quarterly <i>Recommended: Monthly during growing season</i>	Vegetation	Weeds	Weeds on more than 20% of the site	Remove weeds manually.
Required: Annually <i>Recommended: Monthly</i>	Growing medium	Exposed soil	Vegetation should cover 90% of facility	Cover exposed soil with plants and mulch consistent with original design.
Required: Annually <i>Recommended: Monthly from November-April and after large storms (1 inch in 24 hrs).</i>	Growing medium	Erosion	Rill or gully formation	Fill eroded areas with approved soil and lightly compact and replant consistent with original design.

Note: No chemical control measures such as herbicides, insecticides, pesticides, fertilizers, and rodenticides shall be used in post-construction stormwater quality facilities without prior approval from the City of Albany.

Water Quality (Pretreatment) Manhole – O&M Checklist

These facilities provide pre-treatment by settling sediment and large debris. This checklist describes required and recommended inspection and maintenance activities to provide for proper facility function.

Inspection Timing	Facility Feature	Problem	Conditions to Check For	Maintenance Practices
Required: Annually <i>Recommended: Monthly from November - April</i>	General	Trash, debris and sediment	Material exceeds 50% of sump depth or one foot below the Tee or Snout	Remove trash, debris, and sediment.
Required: Annually <i>Recommended: Annually</i>	General	Structural damage	Tee or Snout is not securely attached to manhole wall	Securely attach snout or tee to wall and outlet pipe.
Required: Annually <i>Recommended: Annually</i>	General	Structural damage	Structure is not upright (allow up to 10% from plumb)	Ensure structure is in correct position
Required: Annually <i>Recommended: Annually</i>	General	Structural damage	Connections to outlet pipe are not watertight	Repair or replace structure to work as designed.
Required: Annually <i>Recommended: Annually</i>	General	Structural damage	Any holes in the structure (other than designed)	Repair/replace structure as needed so no holes exist, except as designed.
Required: Annually <i>Recommended: Annually</i>	Manhole	Locking mechanism not working	Mechanism cannot be opened by one maintenance person with proper tools; bolts into frame have less than 1/2 inch of thread (may not apply to self-locking lids)	Replace/repair as necessary to ensure mechanism opens appropriately.
Required: Annually <i>Recommended: Annually</i>	Manhole	Cover not in place	Cover is missing or only partially in place	Replace cover and/or secure cover in place.
Required: Annually <i>Recommended: Annually</i>	Manhole	Cover difficult to remove	One maintenance person cannot remove lid using normal lifting pressure; cover makes access for maintenance difficult	Ensure cover can be removed by one maintenance person.
Required: Annually <i>Recommended: Annually</i>	Manhole	Ladder rungs unsafe	Ladder is unsafe (missing rungs, loose rungs, misalignment, rust, cracks)	Repair or secure ladder immediately. Ladder must meet design standards and allow safe access for maintenance.

Note: Water quality manholes are considered confined spaces and are not designed for prolonged occupancy. Follow industry safety standards when maintaining facilities.

Dry Ponds – O&M Checklist

These vegetated post construction stormwater quality facilities are designed to accept stormwater runoff from development site impervious surfaces. They remove pollutants by filtering runoff through vegetation and soil media. This checklist describes required and recommended inspection and maintenance activities to provide for proper facility function. Note this O&M checklist does not take into account additional requirements for combined treatment and detention facilities.

Inspection Timing	Facility Feature	Problem	Conditions to Check For	Maintenance Practices
Required: Annually <i>Recommended Monthly from November through April and after any large storm (e.g., 1 inch in 24 hrs)</i>	General	Trash and debris	Evidence of trash or debris	Remove trash and debris.
Required: Annually <i>Recommended: Monthly from November through April and after any large storm (e.g., 1 inch in 24 hrs)</i>	Pond Bottom	Sediment accumulation	If sediment accumulation effects proper function or exceeds 6 ins. in forebay or treatment cell	Remove as necessary to maintain proper function
Required: Annually <i>Recommended: Monthly from November through April and after any large storm (e.g., 1 inch in 24 hrs)</i>	General	Standing water	For facilities not providing detention: Standing water in the facility between storms that does not drain freely. No standing water should be present within 48 hrs after any large storm (1 inch in 24 hrs or larger) For facilities providing detention: Standing water for a period in excess of design.	Remove sediment or trash blockages and rake soil to clear debris; remove sediment from clean-outs and clear perforated underdrains as needed.
Required: Annually <i>Recommended: Monthly from November through April and after any large storm (e.g., 1 inch in 24 hrs)</i>	Pond Bottom	Erosion/scour	Evidence of erosion/scour	Repair eroded area with like material. Consult with a licensed Civil Engineer as necessary for assessment and identification of potential corrective actions.
Required: Annually	Embankments	Erosion scour, settlement	Evidence of erosion/scour or settlement	Make repairs following consultation with a licensed Civil Engineer as necessary for assessment and identification of potential corrective actions.
Required: Annually <i>Recommended: Monthly from November through April and after any large storm (e.g., 1 inch in 24 hrs)</i>	Inlets/outlets	Obstructed or non-working inlet/outlet	Inlet/outlet areas clogged with sediment, vegetation or debris; Sediment trap, overflow or clean-out pipes are damaged, or parts are missing.	Remove debris and material as necessary from all features and repair features as necessary to allow for proper function.

Dry Ponds – O&M Checklist (continued)

Inspection Timing	Facility Feature	Problem	Conditions to Check For	Maintenance Practices
Required: Annually <i>Recommended: Monthly from November through April and after any large storm (e.g., 1 inch in 24 hrs)</i>	Liner (if applicable)	Exposed or damaged liner, leaks from lined facility	Exposed or damaged liner with evidence of, or potential for, damage or leakage	Repair or replace liner and restore cover material
Required: Annually <i>Recommended: Monthly from November through April and after any large storm (e.g., 1 inch in 24 hrs)</i>	General	Contaminants and Pollution	Evidence of spills, or excess oil, gasoline, contaminants or pollutants	Remove/cleanup contaminates. Coordinate removal/cleanup with City of Albany Public Works
Required: Annually <i>Recommended: Monthly during growing season</i>	Vegetation	Poor Vegetation Condition/ Coverage	Sparse or dying design planting, or when design plantings are not thriving across 80% or more of the design vegetated areas within the pond	Replace plantings necessary to comply with planting plan requirements
Required: Annually <i>Recommended: Monthly during growing season</i>	Vegetation	Invasive Vegetation	Nuisance weeds present. Invasive vegetation is present, including but not limited to the following: Himalayan Blackberry; Reed Canary Grass; Teasel English Ivy; Nightshade; Clematis; Cattail Thistle; Scotch Broom.	Replace plantings necessary to comply with planting plan requirements
Required: Annually	Vegetation	Undesirable tree/shrub growth	Tree/shrub growth interferes with access for maintenance (e.g., slope mowing, silt removal, vactoring, or equipment movements)	Trim Trees/shrubs, minimally, to not hinder maintenance practices
Required: Annually	Vegetation	Hazard trees	Dead, dying or diseased trees	Remove and replace dead, dying or diseased trees that have become a hazard. Consult with a certified arborist as necessary, tree removal permits may be required
Required: Annually	General	Rodents	Evidence of rodents or water piping through facility via rodent holes	Repair facility, fill rodent holes, and remove rodents
Required: Annually	General	Insects	Nuisance insects (e.g., wasps, hornets, fire ants) that interfere with maintenance activities	Remove insects and nests as needed

Note: No chemical control measures such as herbicides, insecticides, pesticides, fertilizers, and rodenticides shall be used in post-construction stormwater quality facilities without prior approval from the City of Albany.

APPENDIX E.10.05

WATER QUALITY FACILITY DESIGN GUIDE DRAWINGS

PAGE INTENTIONALLY LEFT BLANK.

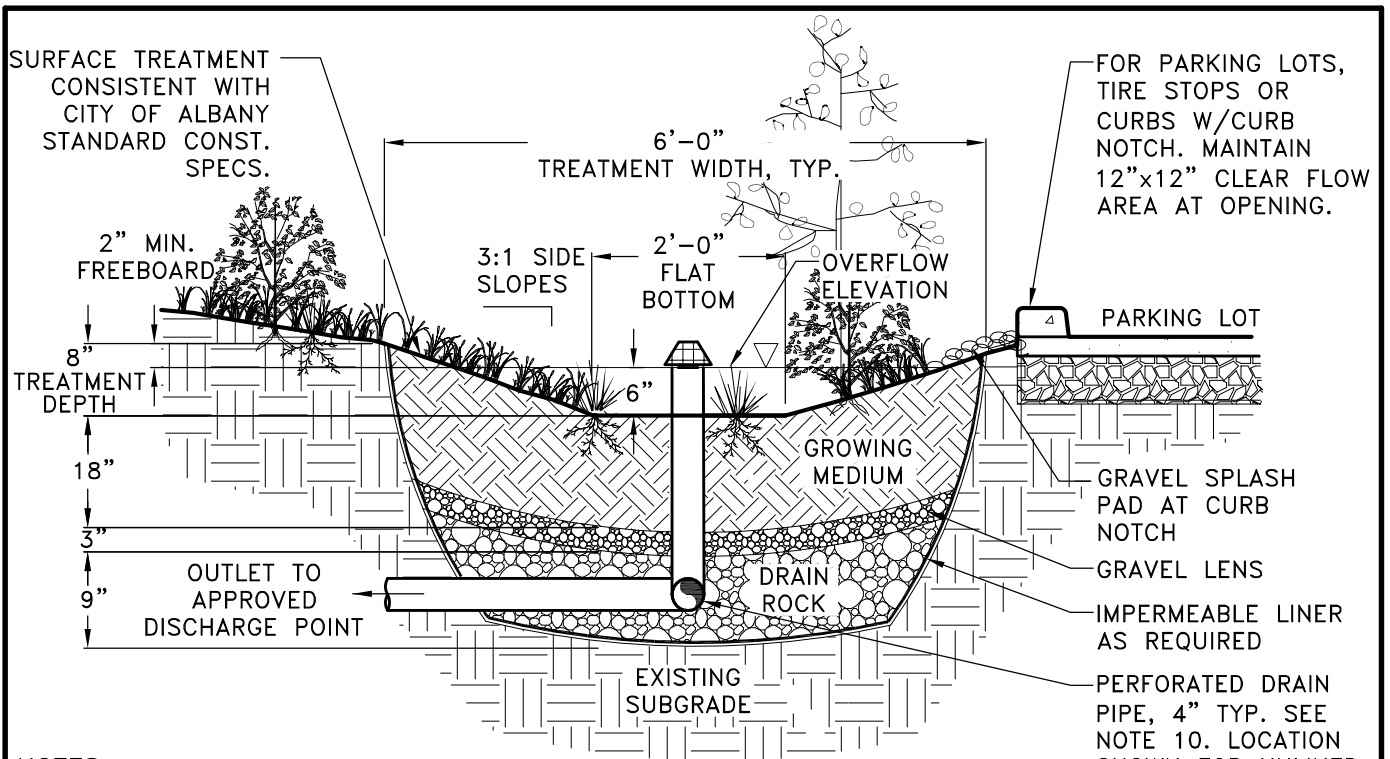

NOTES

1. PROVIDE PROTECTION FROM ALL VEHICLE TRAFFIC, EQUIPMENT STAGING, AND FOOT TRAFFIC IN PROPOSED FACILITY AREAS PRIOR TO, DURING, AND AFTER CONSTRUCTION.
2. THIS SWALE SECTION IS AN EXAMPLE. OTHER DIMENSIONS CAN BE PROPOSED FOR CONSIDERATION.
3. SETBACKS (FROM EDGE OF FACILITY):
 - A. UNLINED SWALES MUST BE 10' FROM FOUNDATIONS AND 5' FROM PROPERTY LINES WHEN INVERT OF UNDER DRAIN IS HIGHER THAN GROUND SURFACE OF ADJACENT PROPERTY.
 - B. MEET ANY CITY OF ALBANY DEVELOPMENT CODE REQUIREMENTS.
4. OVERFLOW:
 - A. OVERFLOW REQUIRED.
 - B. INLET ELEVATION MUST ALLOW FOR 2" OF FREEBOARD, MINIMUM.
 - C. PROTECT FROM DEBRIS AND SEDIMENT WITH STRAINER OR GRATE.
 - D. SIZE TO PASS LARGER STORM FLOWS, AS NECESSARY.
5. DRAIN ROCK: SHALL BE CONSISTENT WITH CITY OF ALBANY STANDARD CONSTRUCTION SPECIFICATIONS.
6. GRAVEL LENS: 3" SEPARATION BETWEEN DRAIN ROCK AND GROWING MEDIUM. SHALL BE CONSISTENT WITH CITY OF ALBANY STANDARD CONSTRUCTION SPECIFICATIONS.
7. GROWING MEDIUM: SHALL BE CONSISTENT WITH CITY OF ALBANY STANDARD CONSTRUCTION SPECIFICATIONS.
8. VEGETATION: DEVELOP PLANTING PLAN PER ENGINEERING STANDARDS.
9. IMPERMEABLE LINER AND LINER PENETRATIONS: IF REQUIRED, SHALL BE CONSISTENT WITH CITY OF ALBANY STANDARD CONSTRUCTION SPECIFICATIONS.
10. IN UNLINED FACILITIES, BOTTOM OF PERFORATED DRAIN PIPE SHALL BE SET AT 2 1/2" ABOVE EXISTING SUBGRADE. IN LINED FACILITIES, BOTTOM PERFORATED DRAIN PIPE SHALL BE SET AT BASE OF DRAIN ROCK LAYER.
11. GRAVEL SPLASH PAD: INSTALL 4" WASHED RIVER ROCK TO TRANSITION FROM CURB NOTCH TO GROWING MEDIUM.
11. CHECK DAMS: USE AS NEEDED TO MAINTAIN FLAT PLANTER SURFACE AND REQUIRED FREEBOARD ON SLOPED SITES. INDIVIDUAL DESIGNS WILL VARY. SEE ALBANY STANDARD CONSTRUCTION SPECIFICATIONS FOR PUBLIC FACILITY EXAMPLE.
12. PLUMBING SHALL CONFORM TO THE OREGON PLUMBING SPECIALTY CODE. OBTAIN PERMITS AS NEEDED FROM CITY OF ALBANY BUILDING DIVISION.
13. SEE ENGINEERING STANDARD TEXT FOR ADDITIONAL STORMWATER QUALITY DESIGN REQUIREMENTS.

CITY OF ALBANY, OREGON PUBLIC WORKS DEPARTMENT	
ONSITE SWALE DESIGN GUIDE	
NO SCALE	JANUARY 2015

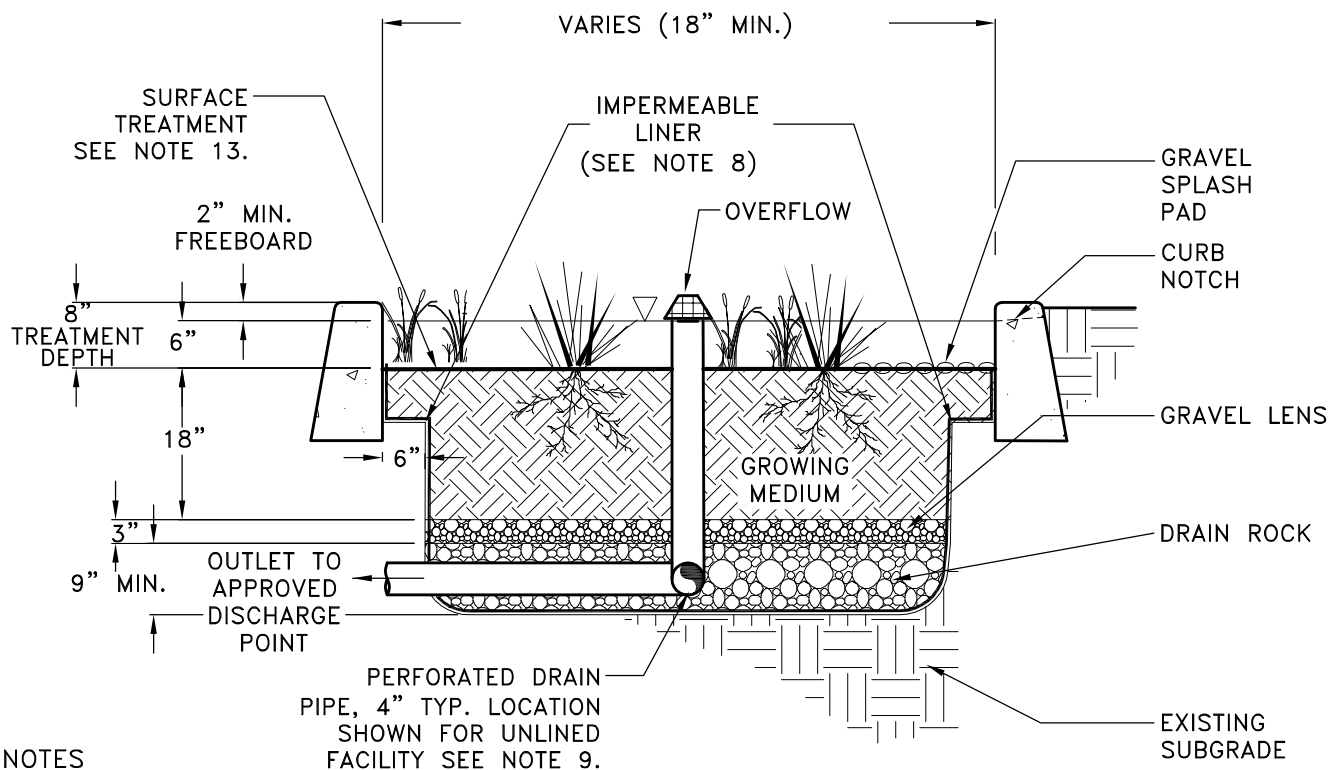

NOTES

1. PROVIDE PROTECTION FROM ALL VEHICLE TRAFFIC, EQUIPMENT STAGING, AND FOOT TRAFFIC IN PROPOSED FACILITY AREAS PRIOR TO, DURING, AND AFTER CONSTRUCTION.
2. SETBACKS (FROM EDGE OF FACILITY):
 - A. UNLINED SWALES MUST BE 10' FROM FOUNDATIONS AND 5' FROM PROPERTY LINES WHEN INVERT OF THE UNDER DRAIN IS HIGHER THAN GROUND SURFACE OF ADJACENT PROPERTY.
 - B. MEET ANY CITY OF ALBANY DEVELOPMENT CODE REQUIREMENTS.
3. OVERFLOW:
 - A. OVERFLOW REQUIRED.
 - B. INLET ELEVATION MUST ALLOW FOR 2" OF FREEBOARD, MINIMUM.
 - C. PROTECT FROM DEBRIS AND SEDIMENT WITH STRAINER OR GRATE.
 - D. SIZE TO PASS LARGER STORM FLOWS, AS NECESSARY.
4. DRAIN ROCK: SHALL BE CONSISTENT WITH CITY OF ALBANY STANDARD CONSTRUCTION SPECIFICATIONS.
5. GRAVEL LENS: 3" SEPARATION BETWEEN DRAIN ROCK AND GROWING MEDIUM. SHALL BE CONSISTENT WITH CITY OF ALBANY STANDARD CONSTRUCTION SPECIFICATIONS.
6. GROWING MEDIUM: SHALL BE CONSISTENT WITH CITY OF ALBANY STANDARD CONSTRUCTION SPECIFICATIONS.
7. VEGETATION: DEVELOP PLANTING PLAN PER ENGINEERING STANDARDS.
8. IMPERMEABLE LINER AND LINER PENETRATIONS: IF REQUIRED, SHALL BE CONSISTENT WITH CITY OF ALBANY STANDARD CONSTRUCTION SPECIFICATIONS.
9. IN UNLINED FACILITIES, BOTTOM OF PERFORATED DRAIN PIPE SHALL BE SET AT 2 1/2" ABOVE EXISTING SUBGRADE. IN LINED FACILITIES, BOTTOM PERFORATED DRAIN PIPE SHALL BE SET AT BASE OF DRAIN ROCK LAYER.
10. CHECK DAMS: USE AS NEEDED TO MAINTAIN FLAT PLANTER SURFACE ON SLOPED SITES. INDIVIDUAL DESIGNS WILL VARY. SEE ALBANY STANDARD CONSTRUCTION SPECIFICATIONS FOR PUBLIC FACILITY EXAMPLE.
11. PLUMBING SHALL CONFORM TO THE OREGON PLUMBING SPECIALTY CODE. OBTAIN PERMITS AS NEEDED FROM CITY OF ALBANY BUILDING DIVISION.
12. SEE ENGINEERING STANDARDS FOR ADDITIONAL DESIGN REQUIREMENTS.
13. SURFACE TREATMENT SHALL BE CONSISTENT WITH CITY OF ALBANY STANDARD CONSTRUCTION SPECIFICATIONS.

CITY OF ALBANY, OREGON PUBLIC WORKS DEPARTMENT	
ONSITE PLANTER DESIGN GUIDE	
NO SCALE	JANUARY 2015

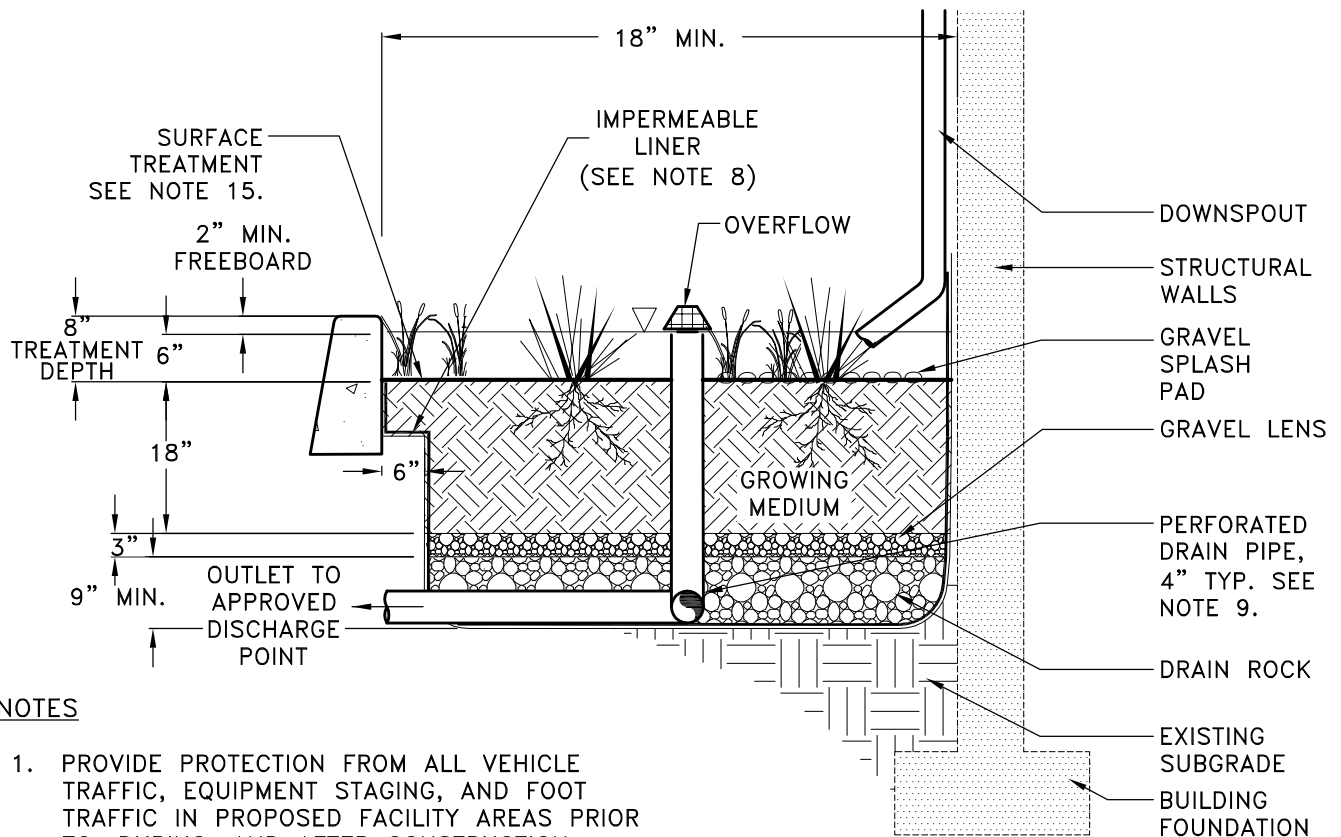

NOTES

1. PROVIDE PROTECTION FROM ALL VEHICLE TRAFFIC, EQUIPMENT STAGING, AND FOOT TRAFFIC IN PROPOSED FACILITY AREAS PRIOR TO, DURING, AND AFTER CONSTRUCTION.
2. SETBACKS (FROM EDGE OF FACILITY):
 - A. MEET ANY CITY OF ALBANY DEVELOPMENT CODE REQUIREMENTS.
3. OVERFLOW:
 - A. OVERFLOW REQUIRED.
 - B. INLET ELEVATION MUST ALLOW FOR 2" OF FREEBOARD, MINIMUM.
 - C. PROTECT FROM DEBRIS AND SEDIMENT WITH STRAINER OR GRATE.
 - D. SIZE TO PASS LARGER STORM FLOWS, AS NECESSARY.
4. DRAIN ROCK: SHALL BE CONSISTENT WITH CITY OF ALBANY STANDARD CONSTRUCTION SPECIFICATIONS.
5. GRAVEL LENS: 3" SEPARATION BETWEEN DRAIN ROCK AND GROWING MEDIUM. SHALL BE CONSISTENT WITH CITY OF ALBANY STANDARD CONSTRUCTION SPECIFICATIONS.
6. GROWING MEDIUM: SHALL BE CONSISTENT WITH CITY OF ALBANY STANDARD CONSTRUCTION SPECIFICATIONS.
7. VEGETATION: DEVELOP PLANTING PLAN PER ENGINEERING STANDARDS.
8. IMPERMEABLE LINER REQUIRED FOR BUILDING PLANTER AND LINER PENETRATIONS SHALL BE CONSISTENT WITH CITY OF ALBANY STANDARD CONSTRUCTION SPECIFICATIONS.
9. BOTTOM OF PERFORATED DRAIN PIPE SHALL BE SET AT BASE OF DRAIN ROCK LAYER.
10. GRAVEL SPLASH PAD: INSTALL 4" WASHED RIVER ROCK TO TRANSITION FROM CURB NOTCH TO GROWING MEDIUM.
11. CHECK DAMS: USE AS NEEDED TO MAINTAIN FLAT PLANTER SURFACE ON SLOPED SITES. INDIVIDUAL DESIGNS WILL VARY. SEE ALBANY STANDARD CONSTRUCTION SPECIFICATIONS FOR PUBLIC FACILITY EXAMPLE.
12. PLUMBING SHALL CONFORM TO THE OREGON PLUMBING SPECIALTY CODE. OBTAIN PERMITS AS NEEDED FROM CITY OF ALBANY BUILDING DIVISION.
13. SEE BUILDING DIVISION STANDARDS FOR ADDITIONAL REQUIREMENTS FOR PLANTERS ADJACENT TO A BUILDING.
14. SEE ENGINEERING STANDARD TEXT FOR ADDITIONAL STORMWATER QUALITY DESIGN REQUIREMENTS.
15. SURFACE TREATMENTS SHALL BE CONSISTENT WITH CITY OF ALBANY STANDARD CONSTRUCTION SPECIFICATIONS.

CITY OF ALBANY, OREGON PUBLIC WORKS DEPARTMENT	
ONSITE PLANTER DESIGN GUIDE (BUILDING PLANTER)	
NO SCALE	JANUARY 2015

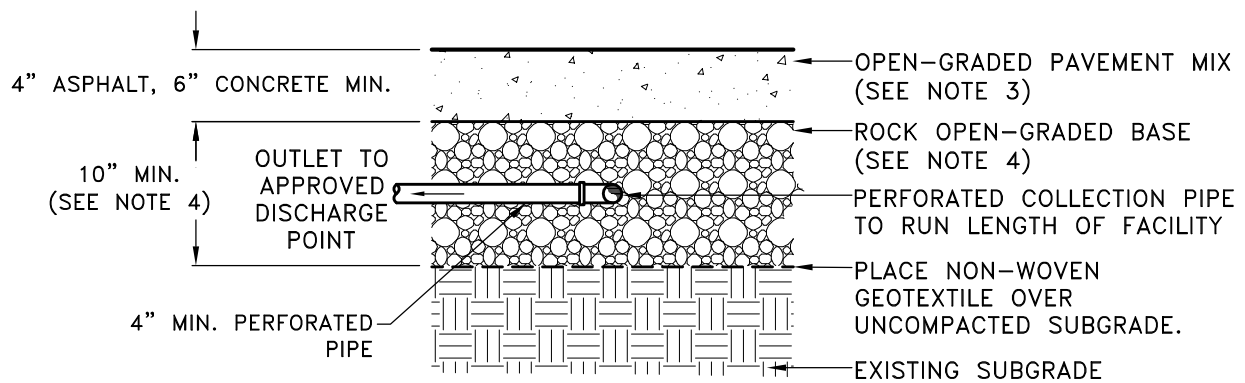

NOTES

1. PROVIDE PROTECTION FROM ALL VEHICLE TRAFFIC, EQUIPMENT STAGING IN PROPOSED FACILITY AREAS PRIOR TO AND DURING CONSTRUCTION.
2. PERVIOUS PAVEMENT SHALL ONLY BE CONSIDERED FOR IMPERVIOUS AREA REDUCTION CREDIT WHEN IT IS DESIGNED WITHOUT ANY IMPERMEABLE LINER.
3. OPEN-GRADED PAVEMENT MIX: SHALL BE CONSISTENT WITH CITY OF ALBANY ENGINEERING STANDARDS. MIX DESIGN REQUIRES APPROVAL OF THE CITY ENGINEER.
4. ROCK OPEN-GRADED BASE: SHALL BE CONSISTENT WITH CITY OF ALBANY ENGINEERING STANDARDS.
5. PLUMBING SHALL CONFORM TO THE OREGON PLUMBING SPECIALTY CODE. OBTAIN PERMITS AS NEEDED FROM CITY OF ALBANY BUILDING DIVISION.
6. SEE ENGINEERING STANDARDS FOR ADDITIONAL STORMWATER QUALITY DESIGN REQUIREMENTS.

CITY OF ALBANY, OREGON
PUBLIC WORKS DEPARTMENT

PERVIOUS PAVEMENT
DESIGN GUIDE

NO SCALE

JANUARY 2015

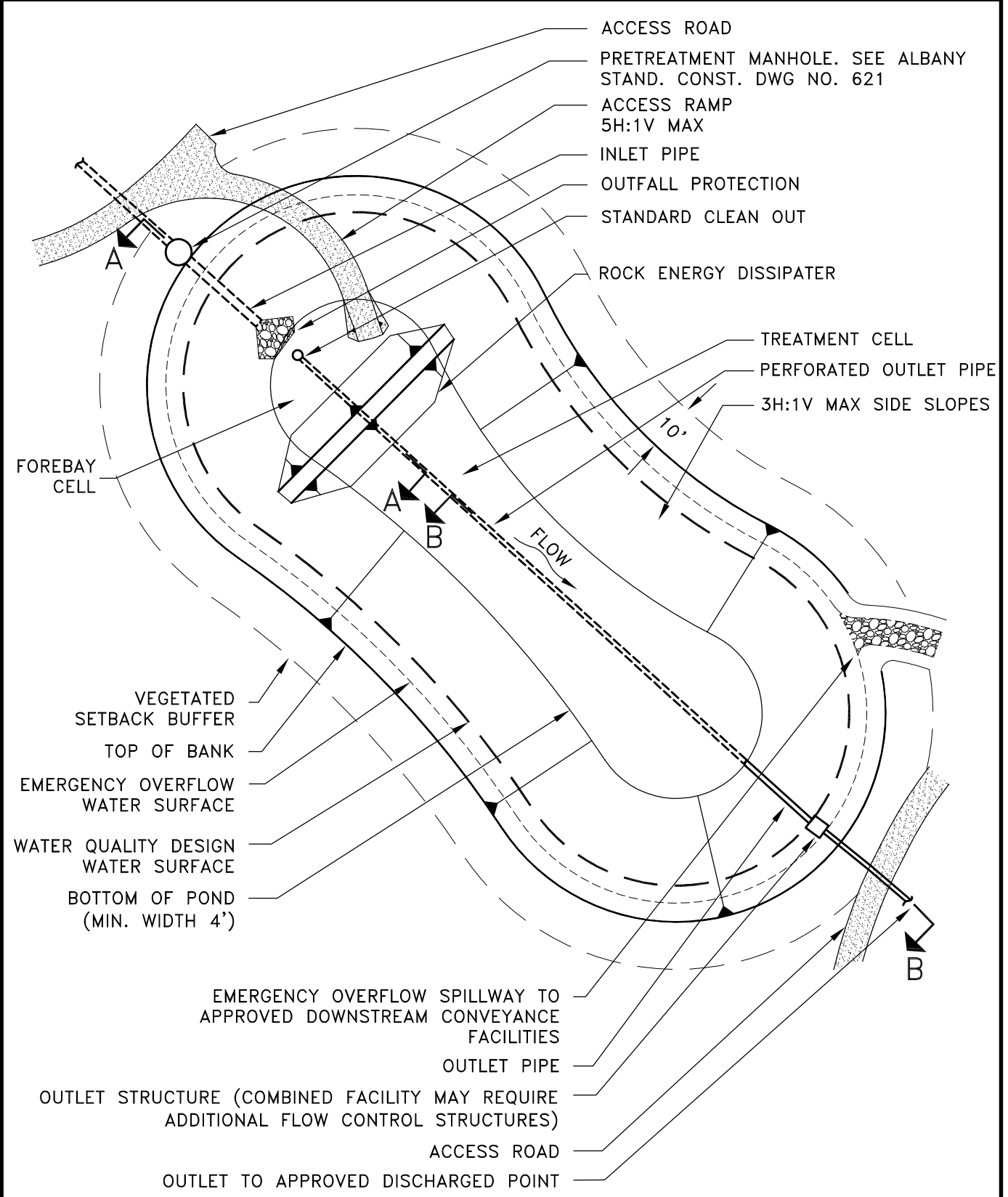

NOTES

- 1. SEE ENGINEERING STANDARDS FOR ADDITIONAL REQUIREMENTS.

CITY OF ALBANY, OREGON PUBLIC WORKS DEPARTMENT	
EXAMPLE DRY POND PLAN VIEW PG 1 OF 3	
NO SCALE	OCTOBER 2019

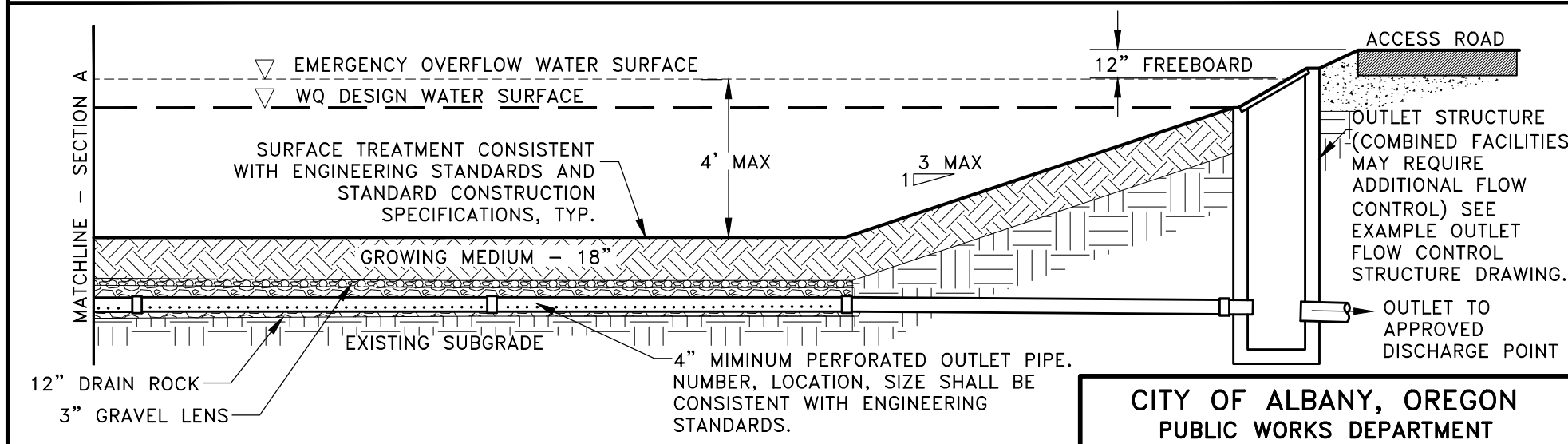
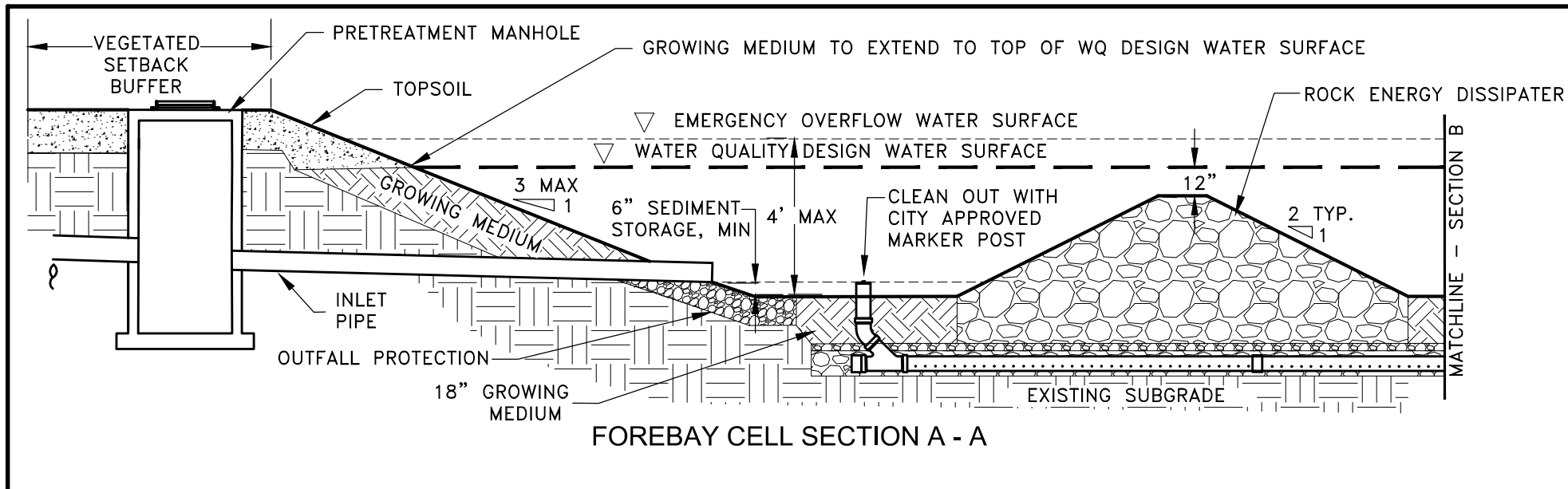

NOTES

1. SEE ENGINEERING STANDARDS FOR ADDITIONAL REQUIREMENTS.

CITY OF ALBANY, OREGON PUBLIC WORKS DEPARTMENT	
EX. DRY POND SECTION VIEW (Pg 2 of 3)	
NO SCALE	OCTOBER 2019

THESE NOTES ARE PROVIDED TO ASSIST IN DESIGN AND PROVIDE ADDITIONAL CLARIFICATION TO THE DRY POND PLAN VIEW AND SECTION VIEW EXAMPLE DRAWINGS. THE SAMPLE PLAN AND SECTION DRAWINGS ARE PROVIDED TO ILLUSTRATE A DESIGN CONSISTENT WITH ENGINEERING STANDARDS. OTHER DIMENSIONS CAN BE PROPOSED TO CITY ENGINEER.

1. PROVIDE PROTECTION FROM ALL VEHICLE TRAFFIC, EQUIPMENT STAGING, AND FOOT TRAFFIC IN PROPOSED FACILITY AREAS PRIOR TO, DURING, AND AFTER CONSTRUCTION.
2. SETBACKS (FROM EDGE OF FACILITY) SHALL BE CONSISTENT WITH ENGINEERING STANDARDS.
3. OVERFLOW SHALL BE CONSISTENT WITH ENGINEERING STANDARDS.
4. SURFACE TREATMENT SHALL BE CONSISTENT WITH THE ALBANY STANDARD CONSTRUCTION SPECIFICATIONS.
5. DRAIN ROCK: SHALL BE CONSISTENT WITH CITY OF ALBANY STANDARD CONSTRUCTION SPECIFICATIONS.
6. GRAVEL LENS: 3" SEPARATION BETWEEN DRAIN ROCK AND GROWING MEDIUM. SHALL BE CONSISTENT WITH CITY OF ALBANY STANDARD CONSTRUCTION SPECIFICATIONS.
7. ROCK ENERGY DISSIPATER: SHALL BE CONSISTENT WITH ENGINEERING STANDARDS.
8. GROWING MEDIUM: SHALL BE CONSISTENT WITH CITY OF ALBANY STANDARD CONSTRUCTION SPECIFICATIONS.
9. VEGETATION: DEVELOP PLANTING PLAN PER ENGINEERING STANDARDS.
10. LINER AS REQUIRED, SHALL BE CONSISTENT WITH CITY OF ALBANY ENGINEERING STANDARDS AND STANDARD CONSTRUCTION SPECIFICATIONS.
11. IN UNLINED FACILITIES, BOTTOM OF PERFORATED DRAIN PIPE SHALL BE SET AT 2 1/2" ABOVE EXISTING SUBGRADE. IN LINED FACILITIES, BOTTOM OF PERFORATED DRAIN PIPE SHALL BE SET AT BASE OF DRAIN ROCK LAYER.
12. PLUMBING SHALL CONFORM TO THE OREGON PLUMBING SPECIALTY CODE. OBTAIN PERMITS AS NEEDED FROM CITY OF ALBANY BUILDING DIVISION.
13. INSTALL CITY APPROVED MARKER POST AT CLEAN OUT.
14. PRETREATMENT MANHOLE: SHALL BE CONSISTENT WITH CITY OF ALBANY ENGINEERING STANDARDS AND STANDARD CONSTRUCTION SPECIFICATIONS.
15. SEE ENGINEERING STANDARDS AND STANDARD CONSTRUCTION SPECIFICATIONS FOR ADDITIONAL STORMWATER QUALITY DESIGN REQUIREMENTS.
16. ALBANY'S STANDARD CONSTRUCTION SPECIFICATIONS SHALL BE USED TO GOVERN MATERIAL TYPES, INSTALLATION PROCEDURES, AND RELATED REQUIREMENTS THEREOF.

CITY OF ALBANY, OREGON
PUBLIC WORKS DEPARTMENT

EXAMPLE DRY POND
GENERAL NOTES
PG 3 OF 3

NO SCALE

OCTOBER 2019

CLAMP DETAIL

ANCHOR TO WALL WITH STAINLESS STEEL RISER CLAMP OR STAINLESS STEEL BAND AND STAINLESS STEEL EXPANSION ANCHORS MIN. 2 PLACES. STEEL BAND TO BE MIN. OF 2" WIDE

1/2" SELF TAPPING CONCRETE ANCHOR PHILLIPS 5-12 OR EQUAL. 1/2"x1 1/2" STAINLESS STEEL BOLT.

SECTION A-A

TOP STEEL BARS (2) 1/4" BAR. UPPER BAR SHALL BE HINGED TO LOWER BAR FOR MAINTENANCE ACCESS. PROVIDE LOCKABLE EYELET FOR CITY-SUPPLIED PADLOCK.

6" LONG 4"x1/4" BAR WITH 1" DIA. HOLE. INSTALL 3"x3/4" ZINK PLATED ALL THREAD INTO TOP OF MANHOLE AND EPOXY INTO PLACE. EMBED ALL THREAD HALFWAY INTO CONCRETE. INSTALL NUTS TO HOLD GRATE IN PLACE.

FLOW CONTROL STRUCTURE GRATE

(32) 1/4" ROUND BAR EQUALLY SPACED

FLOW CONTROL STRUCTURE GRATE

MIDDLE STEEL BAR 1/4" ROUND BAR 4" ABOVE LOWER STEEL BAND 1/4"x4" BAR

(5) 1/4" ROUND BARS @4" O.C. ON TOP OF HINGED GRATE.

FLOW CONTROL STRUCTURE GRATE NOTES:

1. ALL BARS SHALL BE POWDER COATED A36 STEEL
2. ALL BARS SHALL BE WELDED AT ALL CONNECTION POINTS
3. CONTRACTOR SHALL VERIFY ALL EXISTING DIMENSIONS PRIOR TO FABRICATION

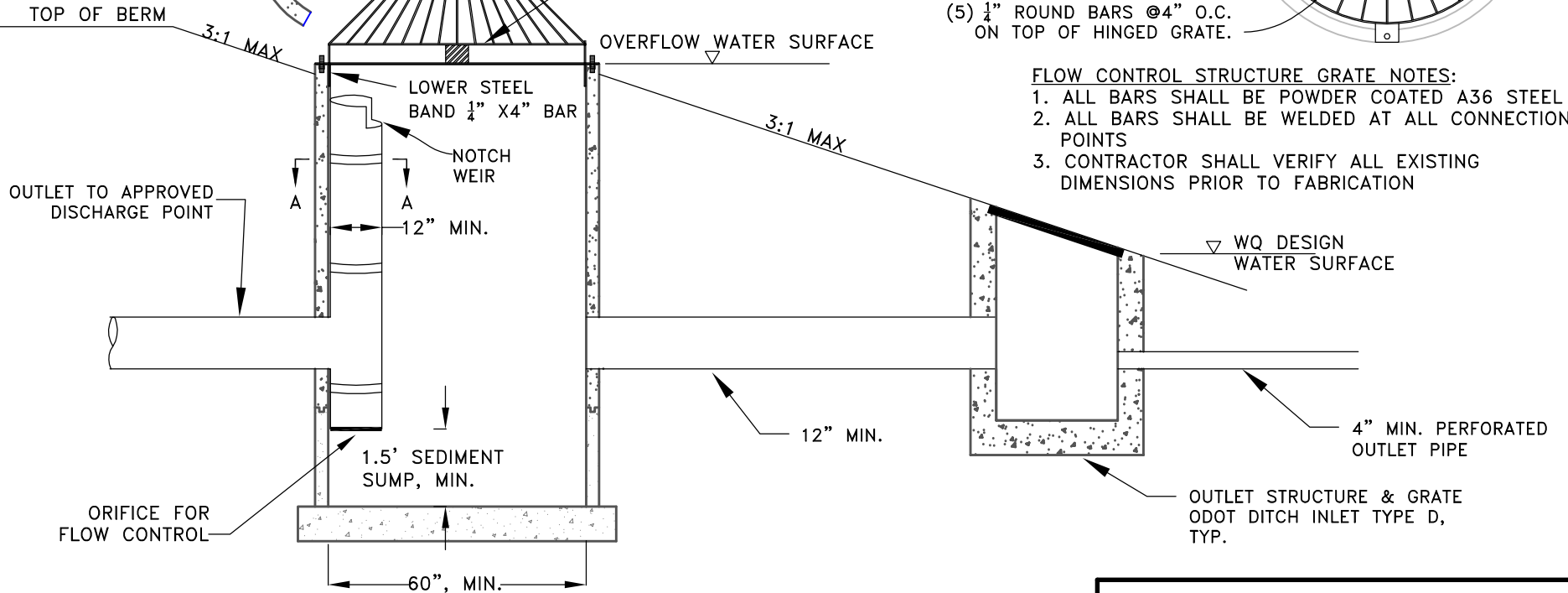

NOTES:

1. A FLOW CONTROL STRUCTURE RESTRICTS FLOW RATES EXITING A POND. THIS EXAMPLE DEPICTS AN ORIFICE FOR THE PRIMARY FLOW CONTROL, WITH A NOTCH WEIR FOR SECONDARY FLOW CONTROL. OTHER OPTIONS INCLUDING PIPE OUTLET MAY BE PROPOSED.
2. MANHOLE, BASES, BARRELS AND CONE SECTIONS SHALL CONFORM TO THE REQUIREMENT OF ASTM C-478 AND APPLICABLE PROVISIONS OF THE STANDARD CONSTRUCTION SPECIFICATIONS DIV. 4 AND STD. MANHOLE DRAWING NO. 408.
3. SEE ENGINEERING STANDARDS AND STANDARD CONSTRUCTION SPECIFICATIONS FOR ADDITIONAL REQUIREMENTS.

**CITY OF ALBANY, OREGON
PUBLIC WORKS DEPARTMENT**

**EXAMPLE
FLOW CONTROL STRUCTURE**

NO SCALE

OCTOBER 2019

This appendix includes methods for both infiltration testing (E.1 through E.4) and depth to groundwater investigations (E.5).

E.1 Infiltration Testing

The following sections provide the approved standard infiltration testing specifications. City staff reserve the right to require additional testing.

E.1.1 Methods and Requirements

To properly size and locate infiltration-based stormwater management facilities, it is necessary to characterize the soil infiltration conditions at the location of the proposed facility. All projects that require an infiltration-based stormwater management facility must evaluate existing site conditions and determine if the site's measured infiltration rate is adequate to support the proposed stormwater management facility.

E.1.2 Testing Criteria

1. Testing must be conducted or observed by a Professional Engineer, Registered Geologist, or Certified Engineering Geologist licensed in the state of Oregon.
2. The depth of the test must correspond to the facility depth.
3. Infiltration testing should not be conducted in engineered or undocumented fill unless an exception is made by a Certified Engineering Geologist consistent with the restrictions and prohibitions outlined in Table 3.02-A in Section E.3.02 of these Engineering Standards.
4. Boring logs must be provided as supporting information with infiltration and depth to groundwater tests.

E.1.3 Depth and Location of Required Tests

Infiltration tests should be performed at the base of the proposed facility. Exceptions can be made to the test location if the qualified professional can support that the strata are consistent from the proposed facility to the test location.

If a confining layer, or soil with a greater percentage of fines, is observed during the subsurface investigation to be within 4 ft of the bottom of the planned infiltration system, the testing must be conducted within that confining layer.

For relatively deep stormwater facilities, a hollow-stem auger with an electronic measuring tape can be used if there is an adequate seal between the auger and the native soil.

E.1.4 Number of Required Tests

The minimum number of infiltration testing locations required is:

- At least one test must be conducted for any proposed facility in the public right-of-way or on a private street.
- One test for every 100 lineal ft or 1,000 square feet of proposed infiltration facility.

- The total number of tests, as long as they meet the minimum requirement, is at the discretion of the qualified professional assessing the site, or as required by the City.
- Where multiple types of facilities are used, it is likely that multiple tests will be necessary, because an infiltration test can test only a single soil stratum. It is highly recommended to conduct an infiltration test at each stratum.

E.1.5 Factor of Safety

For all of the testing methods described in this section, a **minimum allowable factor of safety of 2** must be applied to the field obtained infiltration rates for use in stormwater system design. In other words, the measured infiltration rate should be divided by 2 to obtain the design infiltration rate. The maximum design infiltration rate may not be more than 20 inches per hour.

E.2 Basic Test: Open-Pit Infiltration

The intent of the Open-Pit Infiltration test is to determine whether the local measured infiltration rate is adequate (1.0 inch per hour or more). The Open Pit Infiltration test does not need to be conducted by a licensed professional, but it is recommended.

Basic Test Instructions

1. The open-pit infiltration test must be conducted where the facility is proposed or within the direct vicinity.
2. Excavate a test hole to the depth of the bottom of the infiltration system, or a minimum of 4 ft. The test hole can be excavated with small excavation equipment or by hand using a shovel, auger, or posthole digger.
3. If a layer hard enough to prevent further excavation is encountered, or if noticeable moisture, or groundwater is encountered in the soil, stop and measure this depth from the surface and record it. Proceed with the test at this depth only as consistent with the facility prohibitions and restrictions regarding high groundwater in Table 3.02-A in Section E.3.02 of these Engineering Standards (see also Section G.5 regarding groundwater investigation requirements).
4. Fill the hole with about 6 inches of water (or to one-half the maximum depth of the proposed facility), and record the exact time. Check the water level at regular intervals (every 1 minute for fast-draining soils to every 10 minutes for slower-draining soils) for a minimum of 1 hour or until all of the water has infiltrated. Record the distance the water has dropped from the top edge of the hole.
5. Repeat this process two more times, for a total of three rounds of testing. These tests should be performed as close together as possible to portray the soil's ability to infiltrate at different levels of saturation accurately. The third test provides the best measure of the saturated infiltration rate.
6. For each test pit required, submit all three testing results with the date, duration, drop in water height, and conversion into inches per hour.

7. If the results of the Basic Test show a measured infiltration rate greater than 1.0 inch per hour, the applicant should proceed with facility design (where applicable) for full infiltration/retention facilities.
8. See **Section E.4** for infiltration testing reporting requirements.

E.3 Professional Test

The Professional Test methods must be used for all public and private developments where the Basic Test is not applicable. The qualified professional must exercise judgment in the selection of the appropriate infiltration test method. The three available Professional Test methods to determine a design infiltration rate are:

- Open-pit falling head
- Encased falling head
- Double-ring infiltrometer

E.3.1 Open-Pit Falling Head Procedure

The open-pit falling head procedure is based on the U.S. Environmental Protection Agency (EPA) Falling Head Percolation Test Procedure (Onsite Wastewater Treatment and Disposal Systems Design Manual, EPA/625/1-80-012, 1980). The test is performed in an open excavation and therefore is a test of the combination of vertical and lateral infiltration.

1. Excavate an approximately 2-by-2-foot-wide hole into the native soil to the elevation of the proposed facility bottom (see **Figure E-1**). The test can be conducted in a machine-excavated pit or a hand-dug pit using a shovel, posthole digger, or hand auger. If smooth auguring tools or a smooth excavation bucket is used, scratch the sides and bottom of the hole with a sharp-pointed instrument, and remove the loose material from the bottom of the test hole.

If a layer hard enough to prevent further excavation is encountered, stop and measure this depth from the surface and record it. Proceed with the test at this depth.

If noticeable moisture, or groundwater is encountered, stop and measure this depth from the surface and record it. Proceed with the test only as consistent with the facility prohibitions and restrictions regarding high groundwater in Table 3.02-A in Section E.3.02 of these Engineering Standards (see also **Section E.5** regarding groundwater investigation requirements).

2. A 2-inch layer of coarse sand or fine gravel may be placed to protect the bottom from scour and sloughing.
3. Fill the hole with clean water a minimum of 1 foot above the soil to be tested, and maintain this depth of water for at least 4 hrs (or overnight if clay soils are present) to presoak the native material.
 - Percolation rate measurements must be made between 15 hrs and 30 hrs after the soaking period begins. It is important that the soil be allowed to soak for a sufficiently long period of time to allow the soil to swell if accurate results are to be obtained. Any soil that sloughed into the hole during the soaking period must be removed.
 - In sandy soils with little or no clay, soaking is not necessary. If, after filling the hole twice with 12 inches of water, the water seeps completely away in less than 10 minutes, the infiltration test can proceed immediately.

4. Determine how the water level will be accurately measured. The measurements should be made with reference to a fixed point. A lath placed in the test pit prior to filling or a sturdy beam across the top of the pit are convenient reference points. The tester and excavator should conduct all testing in accordance with Occupational Safety and Health Administration regulations.
5. After the pre-saturation period required in Step 3, refill the hole with water to 12 inches and record the draw-down time.
Measure the water level to the nearest 0.01 foot (1/8 inch) at 10-minute intervals for a total period of 1 hour (or 20-minute intervals for 2 hrs in slower soils) or until all of the water has drained.
6. Successive trials must be run until the measured infiltration rate between two successive trials does not vary by more than 5%. At least three trials must be conducted. After each trial, the water level is readjusted to the 12-inch level. Enter results into the Infiltration Test Data Table (**Figure E-2**).
7. The results of the last water level drop are used to calculate the tested infiltration rate. The final rate must be reported in inches per hour. See the calculation following **Figure E-2**.
8. For very rapidly draining soils, it may not be possible to maintain a water head above the bottom of the test pit. If the infiltration rate meets or exceeds the flow of water into the test pit, conduct the test in the following manner:
 - a. Approximate the area over which the water is infiltrating.
 - b. Using a water meter, bucket, or other device, measure the rate of water discharging into the test pit.
 - c. Calculate the measured infiltration rate by dividing the rate of discharge (cubic inches per hour) by the area over which it is infiltrating (square inches).
 - d. Upon completion of the testing, the excavation must be backfilled.
9. See **Section E.4** for infiltration testing reporting requirements.

E.3.2 Encased Falling Head Procedure

The encased falling head procedure is based on a modification of the EPA Falling Head Percolation Test Procedure (Onsite Wastewater Treatment and Disposal Systems Design Manual, EPA/625/1-80-012, 1980). The most significant modification is that this test is performed with a 6-inch casing that is embedded approximately 6 inches into the native soil. The goal of this field test is to evaluate the vertical infiltration rate through a 6-inch plug of soil, without allowing any lateral infiltration. The test is not appropriate in gravelly soils or in other soils where a good seal with the casing cannot be established.

1. Embed a solid 6-inch-diameter casing into the native soil at the elevation of the proposed facility bottom (see **Figure E-1**). Ensure that the embedment provides a good seal around the pipe casing so that percolation will be limited to the 6-inch plug of the material within the casing. This method can also be applied to testing within hollow-stem augers if the driller and tester are reasonably certain that a good seal has been achieved between the soil and auger.

If noticeable moisture, or groundwater is encountered in the soil, stop and measure this depth from the surface and record it. Proceed with the test only as consistent with the facility prohibitions and restrictions regarding high groundwater in Table 3.02-A in Section E.3.02 of these Engineering Standards (see also **Section E.5** regarding groundwater investigation requirements).

2. A 2-inch layer of coarse sand or fine gravel may be placed to protect the bottom from scour and sloughing.
 - a. Fill the pipe with clean water a minimum of 1 foot above the soil to be tested, and maintain this depth for at least 4 hrs (or overnight if clay soils are present) to presoak the native material.
 - b. Take percolation rate measurements between 15 hrs and 30 hrs after the soaking period begins. It is important that the soil be allowed to soak for a sufficiently long period of time to allow the soil to swell to obtain accurate results. Any soil that sloughed into the hole during the soaking period must be removed and the water level must be adjusted to 6 inches above the added gravel (or 8 inches above the bottom of the hole).
3. In sandy soils with little or no clay, soaking is not necessary. If, after filling the hole twice with 12 inches of water, the water seeps completely away in less than 10 minutes, the test can proceed immediately.
4. To conduct the first trial of the test, fill the pipe to approximately 12 inches above the soil and measure the water level to the nearest 0.01 foot (1/8 inch). The level should be measured with a tape or other device with reference to a fixed point. The top of the pipe is often a convenient reference point. Record the exact time.
5. Measure the water level to the nearest 0.01 foot (1/8 inch) at 10-minute intervals for a total period of 1 hour (or 20-minute intervals for 2 hrs in slower soils) or until all of the water has drained. The infiltration test is continued until the measured infiltration rate between two successive trials does not vary by more than 5%. At least three trials must be conducted. After each trial, the water level is readjusted to the 12-inch level. Enter results into the Infiltration Rate Data Table (see **Figure E-2**).
6. The result of the last water level drop is used to calculate the tested infiltration rate. The final rate must be reported in inches per hour.
7. Upon completion of the testing, the casings must be immediately pulled, and the test pit backfilled.
8. See **Section G.4** for infiltration testing reporting requirements.

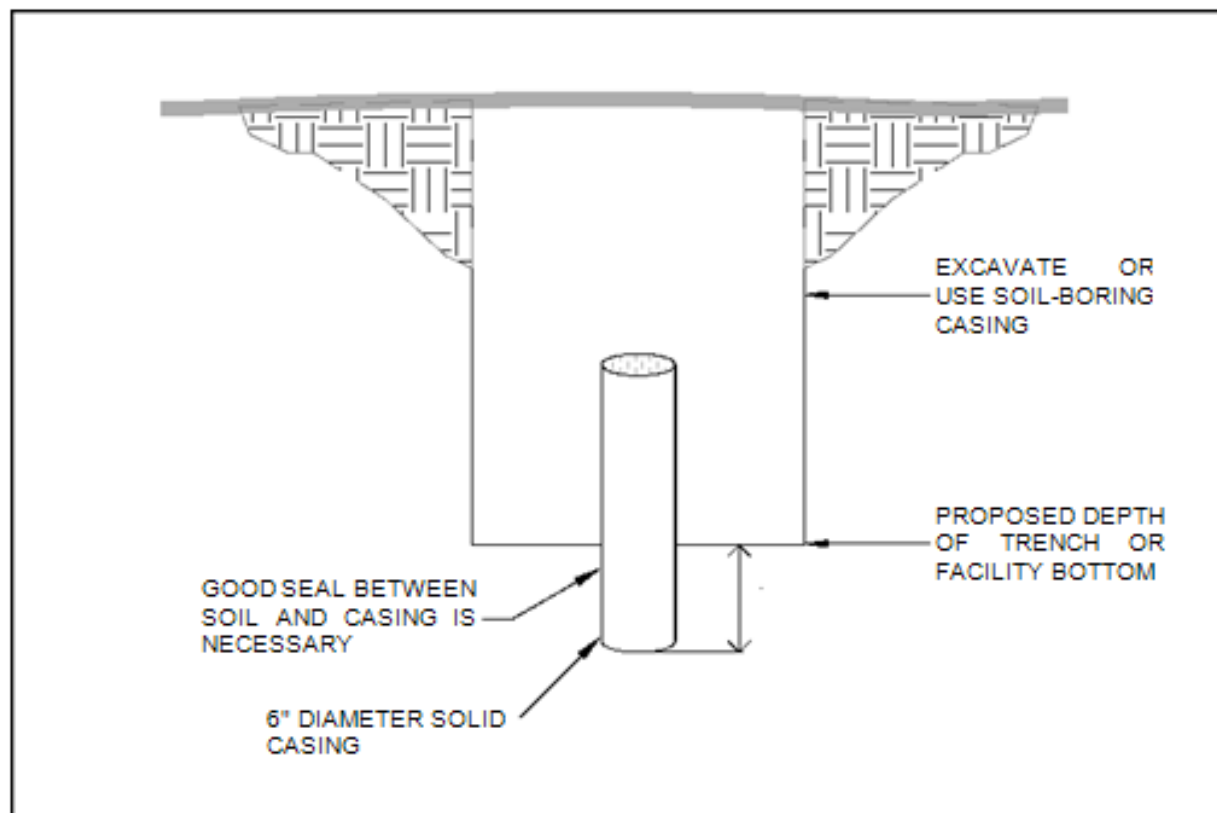

Figure E-1. Encased Falling Head Procedure

E.3.3 Double-Ring Infiltrometer Procedure

The double-ring infiltrometer test procedure must conform with American Society for Testing and Materials (ASTM) 3385-94. The test is performed within two concentric casings embedded and sealed to the native soils. The outer ring maintains a volume of water to diminish the potential of lateral infiltration through the center casing. The volume of water added to the center ring to maintain a static water level is used to calculate the infiltration rate. The double-ring infiltrometer is appropriate only in soils where an adequate seal can be established.

If noticeable moisture, or groundwater is encountered in the soil, stop and measure this depth from the surface and record it. Proceed with the test only as consistent with the facility prohibitions and restrictions regarding high groundwater in Table 3.02-A in Section E.3.02 of these Engineering Standards (see also **Section E.5** regarding groundwater investigation requirements).

The double-ring infiltrometer test may be difficult to perform where the tested soil strata are in a pit, because careful regulation of the static volumes is necessary.

Report infiltration testing results as required in the next section.

E.4 Reporting Requirements

All testing data must be documented with the project submittals. The submittals must adequately demonstrate that the proposed facilities (1) are appropriate to the assessment and characterization of the site, (2) will work, based on in situ infiltration tests, and (3) are sized appropriately, based on design infiltration rates (i.e., measured infiltration rate with factor of safety applied).

The following information should be included in the infiltration testing documentation:

1. Measured infiltration testing results in inches per hour.
2. Location and depth of excavation. For facilities that rely on infiltration for management of the Water Quality Design Storm, the excavation should be deep enough to verify that there is a 3-foot separation between the final depth of the facility (rock gallery) and the seasonal high groundwater or soil layer that could reduce the infiltration rate. For facilities that do not rely on infiltration for management of the Water Quality Design Storm, the excavation should be deep enough to verify that the seasonal high groundwater is below the final depth of the facility.
3. Summary and discussion of infiltration testing, including number of tests, amounts of water used in each test (inches, gallons, etc.), and time of each test. Testing is required to show that an accurate rate was achieved.
4. Discussion of how the test was performed:
 - a. Encased falling head: pipe type, embedment depth, size of pipe
 - b. Double-ring infiltrometer: pipe type, embedment depth, size of pipe
 - c. Open pit: size of area
5. Soil types with depth.
6. Groundwater observations: seasonal high groundwater level estimation (See **Section E.5**).

Location:		Date:		Test Hole Number:	
Depth to bottom of hole:		Diameter of hole:		Test Method:	
Tester's Name: _____					
Tester's Company: _____			Tester's Contact Number: _____		
Depth, ft			Soil Texture		
Time	Time interval, minutes	Measurement, ft	Drop in water level, ft	Percolation rate, inches/hour	Remarks

Figure E-2. Infiltration Test Data Table

Calculation is performed for each water level drop

$$= (\text{Drop in water level} / \text{Time interval}) \times \text{conversion}$$

$$= 0.055 \text{ ft} / 20 \text{ min} \times (12 \text{ in./ft}) \times (60 \text{ min/hr})$$

$$= 1.98 \text{ inches per hour}$$

The design infiltration rate of two successive trials must have a difference of 5% or less.

Figure E-3 shows an example of a completed infiltration test data table.

Location: Lot 105, Low Point Heights Subdivision		Date: 6/28/2010		Test Hole Number: 3	
Depth to bottom of hole: 57 inches		Diameter of hole: 0.5 foot		Test Method: Encased Falling Head	
Tester's Name: C.J. Tester					
Tester's Company: Tester Company Tester's Contact Number: 555-1212					
Depth, ft			Soil Texture		
0-0.5			Black topsoil		
0.5-1.0			Brown SM		
1.0-2.2			Brown ML		
2.2-5.1			Brown CL		
Time	Time interval, minutes	Measurement, ft	Drop in water level, ft	Percolation rate, inches/hour	Remarks
9:00	0	3.75	-		Filled with 6"
9:20	20	3.83	0.08		
9:40	20	3.91	0.08	2.88	
10:00	20	3.98	0.07	2.52	
10:20	20	4.04	0.06	2.16	
10:40	20	4.11	0.07	2.52	
11:00	20	4.17	0.06	2.16	
11:20	20	4.225	0.055	1.98	
					Adjusted to 6" level for Trial 2

Figure E-3. Infiltration Test Data Table Example

E.5 Depth to Groundwater Investigations

Many areas of Albany are known to have shallow groundwater. The City will require a depth-to-groundwater investigation report if the applicant is proposing a facility that relies on infiltration for management of the Water Quality Design Storm (i.e., a facility designed to infiltrate the Water Quality Design Storm event of 1 inch in 24 hrs). The purpose of the investigation is to ensure that seasonal high groundwater neither inundates the facility nor prevents the facility from draining between storm events. The base of full infiltration facilities (i.e., base of the drain rock) must be at least 3 ft above the seasonal high groundwater unless otherwise approved by the City.

When boring logs and depth-to-groundwater investigations are required, they must be completed by an Oregon licensed geotechnical engineer, certified engineering geologist, or registered geologist. The following steps are for the exploratory boring work and depth-to-groundwater investigation:

Steps for Exploratory Boring Work and Depth-to-Groundwater Investigation

Step No.	Action
1.	Select the location for the boring at the location of the proposed infiltration facility.
2.	Call the Oregon One-Call Center at 1-800-332-2344 to locate all underground utilities.
3.	Construct borings in compliance with the Oregon Water Resources Department's Oregon Administrative Rules Chapter 690, Division 240. Oregon Secretary of State Administrative Rules .
4.	For infiltration stormwater facilities with a proposed total depth of 5 ft or less, advance the boring to a minimum of 15 ft below the bottom of the proposed stormwater facility; for stormwater facilities deeper than 5 ft, advance the boring to at least 20 ft below the bottom of the proposed stormwater facility.
5.	Continuous soil sampling is recommended to allow detailed characterization of subsurface soil and identification of groundwater depth.
6.	If groundwater is encountered, monitor it as described below; otherwise, skip to Step 7. <ul style="list-style-type: none"> a) For fine-grained soils only, allow water levels to equilibrate for a minimum of 1-hour before measuring the depth. b) After the water level has stabilized, use an electronic water level indicator or a weighted tape to measure the depth to groundwater relative to ground surface to the nearest 1/8 inch (~0.01 ft). Take measurements until two measurements taken at least 15 minutes apart differ by less than 1/8 inch. c) If the boring is conducted in the months of June through February, subtract the seasonal correction factor of 10 ft from the measured depth to groundwater to calculate the estimated depth to seasonal high groundwater. In other words, the depth to seasonal high groundwater equals the measured depth to groundwater minus the 10 ft.
7.	Abandon borings in accordance with Oregon Administrative Rules Chapter 690, 240.
8.	Submit the boring log of subsurface conditions to the City. If groundwater was encountered in the boring, it must be noted on the drilling log.